



JP HYDRAULIC WINCH OWNERS MANUAL

WINCH MODELS:

10JP, 13JP, 15JP, 20JP, 25JP, 30JP

ENGLISH



Doc-rev 20230420

SAVE THESE INSTRUCTIONS. This manual contains important safety precautions which should be read and understood before operating the product. Failure to do so could result in serious injury. Specifications, descriptions and images in this manual are as accurate as known at the time of publication, but are subject to change without notice.

INTRODUCTION

Congratulations on your purchase of a winch. We design and build winches to strict specifications and with proper use and maintenance your winch should bring you years of satisfying service.

Every effort has been made to ensure the accuracy and completeness of the information in this manual at the time of publication, and we reserve the right to change, alter and/or improve the product and this document at any time without prior notice.

SAFETY DEFINITIONS

Your winch can develop tremendous pulling forces and if used unsafely or improperly could result in property damage, serious injury or death. Throughout this manual, you will find the following symbols for caution, warning and danger. Pay particular attention to the notes preceded by these symbols as they are written for your safety. Ultimately, safe operation of this device rests with you, the operator.

DANGER

DANGER indicates a hazardous situation which, if not avoided, will result in death or serious injury.

WARNING

WARNING indicates a hazardous situation which, if not avoided, could result in death or serious injury.

CAUTION

CAUTION indicates a hazardous situation which, if not avoided, could result in minor or moderate injury.

NOTICE

NOTICE indicates information considered important, but not hazard-related (e.g., messages relating to property damage).

GETTING TO KNOW YOUR WINCH

Your winch is a powerful piece of machinery. It is important that you understand the basics of its operation and specifications so that when you need to use it, you can use it with confidence and safety. Below is a list of the components of your winch and their uses.

1. This winch is engineered for maximum line pull with only one layer of cable spooled onto the winch drum (the first layer).
2. Motor: The motor is powered by a 12/24-volt battery and provides power to the gear assembly which turns the drum and winds the wire rope in a direction.
3. Winch Drum: The winch drum is the cylinder on which the wire rope is stored. It can be spooled In or Out by use of the remote lead switch.
4. Wire Rope: Your winch has a galvanized aircraft cable designed specifically for load capacity of the rated line pull of this winch. The wire rope feeds on from underneath the drum position, it is looped at one end to accept the hook.
5. Fairlead (Not Included): For when using the winch at an angle the roller fairlead acts to guide the rope onto the drum evenly and minimizes damage to the rope or winch from abrasion.
6. Gear Assembly System: The reduction gears convert the winch motor power into extreme pulling forces.
7. Braking System: Braking action is automatically applied to the winch when the winch motor is stopped or there is a load on the wire rope. This is achieved by a separate external mechanical brake which applies the braking action. (Brakes are NOT designed as securing devices and the winch cables should never be left attached when vehicle / equipment is in transport).
8. Free Spooling Clutch: The clutch allows the operator to manually disengage ("CLUTCH OUT") the spooling drum from the gear train. This is called free spool. Engaging the clutch ("CLUTCH IN") locks the winch into the gear system.
9. Solenoid: Power from the vehicle battery flows through the weatherproof switch before being directed to the winch motor.
10. Wired Remote lead Switch: The remote switch leads have a dual switch for powering in or powering out your winch drum. The remote control allows you to stand clear of the wire rope when the winch is under load.
11. Wireless remote (Not included): This is designed and offered for 'Offroad' or 'None Commercial' use only and is not included in any warranty offered. This allows the operator to always control the winch from up to 50 Ft away.
12. Universal Flat Bed Mounting Channel: (Optional) Your winch could have been optionally supplied with a flat bed mounting channel that can be mounted to most flat surfaces such as trailers, truck beds and structures etc. The mounting channel also has a number of mounting holes and holes to accept your roller fairlead.
13. Pulley/Snatch Block: (Optional) If your winch is supplied with a pulley/snatch block which can double the pulling power of the winch, or change the pulling direction without damaging the wire rope. We recommend you to use a double line and snatch block for pulling over 70% of the rated line pull.

IMPORTANT SAFETY INSTRUCTIONS

DANGER

DO NOT EXCEED RATED CAPACITY.

INTERMITTENT USE ONLY - COOL BETWEEN USES.

DO NOT use winch for lifting/moving people or live animals.

A minimum of five wraps of cable around the drum barrel is necessary for pulling and holding the rated load. The cable clamp is not designed to hold the load without the 5 wraps of cable around the drum. (usually marked red on the drum end of the cable)

DANGER

Keep yourself and others a SAFE DISTANCE to the side of the cable when under tension.

NEVER stand or step over a cable, or near a cable under load using a winch blanket or sail is strongly recommended.

DON'T move the vehicle to pull a load (towing) on the winch cable. This could result in cable breakage.

DANGER

DO NOT exceed maximum pull rating. Avoid “shock loading” by using the remote lead switch intermittently to take up the slack in the wire rope. “Shock loading” can far exceed the rated capacity for the wire rope and drum and will result in damaging winch and brake. By doing so will void any warranty.

DANGER

DO NOT use you winch as securing device it is not designed for this and will result in damaging winch and brake and will void any warranty.

DO NOT exceed maximum line pull ratings shown on the tables.

DO NOT use as a hoist. Do not use for overhead lifting.

DANGER

NEVER cut, weld, or modify any part of the winch or cable. By doing so will void any warranty

DANGER

When re-spooling the cable Ensure that the cable spools in the under-wind position with the cable entering the drum from the bottom, not the top. To re-spool correctly, and while wearing gloves, keep a slight tension on the cable while pushing the remote control button to draw in the cable. Walk toward the winch **NEVER** allowing the winch cable to slide through your fingers or hands.

DO NOT let your hands get within 12”(30cm) of the winch while re-spooling. Turn off the winch and repeat the procedure until a few feet of cable is left. Disconnect the remote control and finish spooling by hand by rotating the drum manually with the clutch disengaged. Keep hands clear of the fairlead and drum while the winch is under power.

DANGER

Failure to read and understand these warnings may result in personal injury and/or property damage.

Always use gloves to protect hands when handling any type of cable/rope. Never let the cable slide through your hands.

NEVER connect the cable back to itself.

Always apply blocks/chocks/straps to the wheels of the vehicle/equipment when on an incline and in transportation.

No modifications, alterations, or deviation to the winch are authorized by the manufacturer and **MUST NOT** be made. By doing so will void any warranty.

Duration of winching pulls should be kept as short as possible. If the motor becomes uncomfortably hot to the touch, stop winching immediately and let it cool down for approx 8 mins minutes. Do not winch for more than two minutes at or near the maximum rated load without resting for 8 minutes.

DANGER

If the motor stalls **DO NOT** maintain winching. Winches are designed and made for intermittent use and should be used in conjunction with their duty cycles.

NEVER release the free-spool clutch when there is a load on the winch as the load will roll backwards.

Use hand saver hook when handling the hook for spooling or unspooling the wire rope.

NOTICE

The winch and its all-derivative types are rated at rated capacity when spooling the first rope layer on the drum. Overloading can damage the winch / motor / or wire rope.

For loads over 70% of rated line pull, we recommend the use of the pulley block / snatch block to double the wire rope line and reduce the strain. This will aid in two ways:

It will reduce the number of rope layers on the drum and reduce the load on the wire rope by as much as 50%. When doubling the lineback to the vehicle, always attach to the frame or another load bearing point..

NOTICE

The vehicle engine should always be kept running during winching operation to minimize battery drain and maximize power and speed of the winch. If the winch is used for a considerable amount of time with the engine switched off the battery will drain and be too weak to restart the vehicle engine. If this happens stop winching immediately, jump start the vehicle and charge the battery up before resuming winching operation.

NOTICE

Get to know your winch before you need to use it. We recommend that you set up a few test runs to familiarize yourself with rigging techniques; the sounds your winch makes under various loads and the way the cable spools on the drum, etc.

INSPECT the wire rope and equipment before each use. A frayed or damaged rope must be replaced immediately. Use only manufacturer's identical replacement rope with the exact specifications. (Ropes are not covered by any warranty offered)

INSPECT the winch installation and bolts to ensure that all bolts are tight before each operation or periodically.

NOTICE

Store the remote control lead inside your vehicle or in a safe place.

Never connect the winch cable back to itself. This will cause cable to damage. Always use a pulley, snatch block, sling or chain of suitable strength as shown in the illustrations.

NOTICE

Any winch that appears to be faulty, damaged, worn, or operates abnormally **MUST BE REMOVED FROM SERVICE UNTIL REPAIRED, REPLACED OR OVERHAULED**. It is recommended that the necessary repairs **ARE** made by a manufacturer's authorized repair facility **ONLY**.

NOTICE

Pull only on areas of the vehicle as specified by the vehicle manufacturer.

- Only accessories, attachments and/or adapters supplied by the manufacturer shall be used.

CAUTION

When using the tool, basic safety precautions should always be followed to reduce the risk of personal injury and damage to the equipment. Read all these instructions before using this tool!

WARNING

Keep children away. Children must never be allowed in the work area. Do not let them handle machines, tools, extension cords or operate this tool.

WARNING

Store idle equipment. When not in use, tools must be stored in a dry location to inhibit rust. Always lock up tools and keep out of reach of children.

CAUTION

Dress properly. Do not wear loose clothing or jewelry as they can be caught in moving parts. Protective, electrically non-conductive clothes and non-skid footwear are recommended when working. Wear restrictive hair covering to contain long hair.

WARNING

Use eye and ear protection. Always wear impact safety goggles. Wear a full-face shield if you are producing metal filings or wood chips. Wear a dust mask or respirator when working around metal, wood, and chemical dusts, and mists.

CAUTION

Maintain this winch with care. Keep this tool dry and clean for better and safer performance. Follow instructions for lubricating and changing accessories. Inspect winch rope periodically and, if damaged, have them replaced immediately by an authorized technician. The handles must be kept clean, dry, and free from oil and grease always.

Disconnect or unplug remote switch when not in use.

DANGER

Stay alert, watch what you are doing, use common sense. Do not operate any tool when you are tired.

WARNING

Check for damaged parts. Before using this winch, any parts that appear worn or damaged should be carefully checked to determine that it will operate properly and perform to its intended function. Check for damage including alignments, binding of moving parts; mounting fixtures. Any part that is damaged should be properly repaired or replaced by a qualified person. Do not use the tool if any switch does not turn "On" and "Off" properly.

WARNING

Replacement parts and accessories. When repairing or servicing, only use identical replacement parts. The use of any other parts will void the warranty.

⚠ WARNING

Do not operate tool if under the influence of alcohol or drugs. Read warning labels on prescription to determine if your judgment or reflexes are impaired while taking drugs. If there is any doubt, do not operate the tool.

⚠ DANGER

Keep hands and body away from Fairlead (cable intake slot) when operating.

Always secure vehicle in position before using winch.

⚠ WARNING

Be certain the winch is properly bolted to a structure (or vehicle) that can hold the winches maximum rated load.

Do not use inappropriate attachments to extend the length of the winch cable.

⚠ DANGER

Never lift people or hoist loads over people or lift live animals.

Never come in between the winch and the load when operating.

⚠ WARNING

Do not apply any loads to the winch when cable is fully extended past the safety mark. Keep at least 5 full wraps of cable on the spool, (Usually marked red on the winch cable at the drum end.)

After moving any piece of equipment with the winch, secure the the equipment in place. Do not rely on the winch to hold for an extended period of time nor whilst in transport, winches are not securing device, By doing so will void any warranty

⚠ CAUTION

Examine winch before using. Components may be affected by exposure to chemicals, salts, and rust.

Do not cross over or go underneath winch cable when under load.

Use gloves while handling cable.

⚠ WARNING

Never operate winch if cable shows any signs of weakening, such as knotting or kinking. If it does you must replace immediately.

⚠ DANGER

Do not move your vehicle with the cable extended and attached to the load. You could easily exceed the winch rating and snap the cable.

When the vehicle is parked on an incline you should use wheel chocks.

⚠ CAUTION

Always re-spool cable neatly after any operation this will avoid any winch cable misalignment for the next use

⚠ CAUTION

The winch cable must be wound onto the drum under a load of at least 10% of the rated line pull or the outer wraps will draw into inner wraps and damage winch cable.

Before operating the winch under load you should check proper function of the winch by engaging and disengaging the clutch, by operating the directional controls, and operating the speed controls. This will ensure that the winch is working properly and will help prevent unintended damage and injury. Cycling the winch prior to loading will also ensure the gears are properly aligned.

⚠ CAUTION

Batteries contain gases which are flammable and explosive. Wear eye protection during installation and remove all jewelry. Do not lean over battery while making connections.

⚠ WARNING

It is **strongly recommended** a battery isolator is installed to protect vehicle, equipment and user from hazardous situations, if one isn't supplied it is recommended one is purchased and installed before operation of the winch.

Failure to install a battery isolator or safety cut off could result in damage to the vehicle, equipment and(or) operator and will result in voiding any warranty offered.

WINCH ASSEMBLY AND MOUNTING

- **Installing:** Your new winch is designed with a bolt pattern that is standard in this class of winch. A winch mounting kit may be available that utilizes this bolt pattern, If you cannot find a kit locally, you may have to have one engineered, contact a local engineering company. If you utilize a mounting channel, you must ensure that it is mounted on a flat surface so that the three major sections (motor, drum and gear housing) are properly aligned. Improper alignment of the winch will cause uneven distribution of load and damage the winch or equipment. Mount the winch to the vehicle using high tensile steel bolts. It should be aligned and secured to a solid part of the vehicle (front or rear) where the full rated load will be evenly distributed without causing damage to vehicle or equipment.
- **Mounting The Balance Valve:** The balance valve supplied should be already connected to motor. Be sure the balance valve's installing direction meets hydraulic principal chart. Otherwise, the winch will not reach the rated line pull, and it is also dangerous for winch to power off the cable with heavy load. If this symptom happens, simply disconnect the balance valve: exchange the oil hole between hydraulic motor and balance valve, while your winch is working in different direction, change A→C1,B→C2 into A→C2,B→C1. And reconnect it. If your winch is supplied with a balance valve it will have been factory connected with the motor.

- **Plumbing Connections:** Keep all hoses away from any areas where heat may be considered too extreme such as an exhaust, turbo or any moving parts. Lines should not be allowed to rub on any rotating, abrasive, or vibrating surfaces. In some applications, 90° fittings on the directional valve and motor or balance valve are necessary to make hose mounting more flexible. After plumbing has been laid out on vehicle, install O-ring seals to valves and connections.. Torque tight. Do not over tighten any fittings. Install O-ring seals on Winch Motor. Torque tight. Connect any hose port A on motor or port V1 on balance valve to port A on directional valve, port B on motor or port V2 on balance valve to port B on directional valve, port P on directional valve to pump’s high-pressure port, port T on valve to reservoir, if necessary Connect any hose port on valve to steering box. Attach any O-ring or seal from vehicles original tube fitting to tube fitting.

center and closed-center. An open center valve allows a continuous flow of system hydraulic fluid through the valve even when the selector is not in a position to actuate a unit. A closed-center selector valve blocks the flow of fluid through the valve when it is in the NEUTRAL or OFF position.

Selector valve choice as follows:

(H type and Y type are available, O type and M type is not available)

There are three positions for the selector valve. This means the Solenoid directional/selector valve spool has three working positions, both ends of the valve are solenoid coil control action.

- ‘A’ coil is energized, and ‘B’ coil is powered off, the spool moves to the direction of the ‘A’ coil.
- ‘B’ coil is energized, and ‘A’ coil is powered off, the spool moves in the direction of the ‘B’ coil.
- ‘A’ and ‘B’ coils are powered off at the same time, the solenoid valve spools back to the middle position, forming a closed loop, that is, the two chambers of the cylinder are completely closed, resulting in no movement.

The valve has four channels: P, T, A and B.

‘P’ is for oil In, ‘T’ is for oil Out, ‘A’ and ‘B’ is for output.

When the electromagnet is not energized, the reversing valve is in the middle position. The PTAB is connected to each other in the middle of ‘H’ type. In the middle position of ‘Y’, TAB is connected to each other, and P is disconnected from other routes. Type O directional valve in the PTAB access is blocked. In the middle position of ‘M’ type, PT communicates with each other, ‘A’ does not communicate with other, and ‘B’ does not communicate with other.

“H” type: all oil ports are connected, the system is unloaded, and the cylinder is floating. Hydraulic cylinder is connected to oil tank in two chambers, from static stop to start impact. When braking, the oil port is interconnecting, and the braking is more stable than the “O” type, but the reversing position changes greatly.

“Y” type: the oil pump does not unload, the hydraulic cylinder is connected to the oil tank in two chambers, there is impact from rest to start, and the braking performance is between “O” type and “H” type.

“O” type: all oil ports are closed and the system does not unload. Hydraulic cylinder filled with oil, smooth from rest to start. When braking motion inertia caused by hydraulic impact. High accuracy of reversing position.

“M” type: oil pump unloading, from rest to start smoothly. The braking performance is the same as the “O” type.

HYDRAULIC PRINCIPAL CHART AND INSTALLATION:

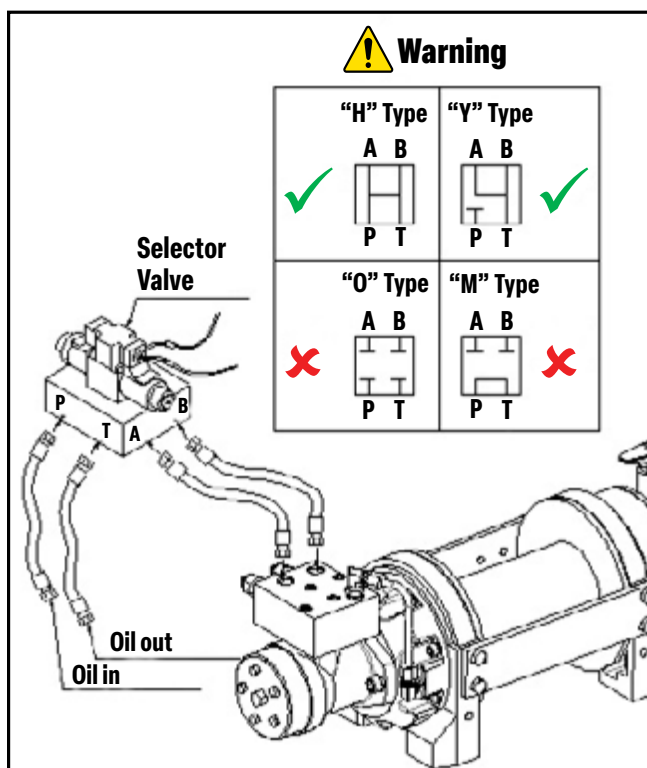

Hydraulic control valves are an essential component for optimizing system performance. They’re used to regulate the flow rate and pressure of the hydraulic oil as it passes through a hoses or pipes, always maintaining the speed and pressure.

Hydraulic flow control valves are adept at controlling the flow of these liquids from the pumps to cylinders and motors. Their primary function is to regulate the flow and direction rate within a specific area of a hydraulic circuit. At the same time, they also control the transfer rate of energy across all pressure levels.

A selector valve is used to control the direction of movement of a hydraulic actuating cylinder or similar device. It provides for the simultaneous flow of hydraulic fluid both into and out of the unit. Hydraulic system pressure can be routed with the selector valve to operate the unit in either direction or a corresponding return path for the fluid to the reservoir is provided. There are two main types of selector valves: open-

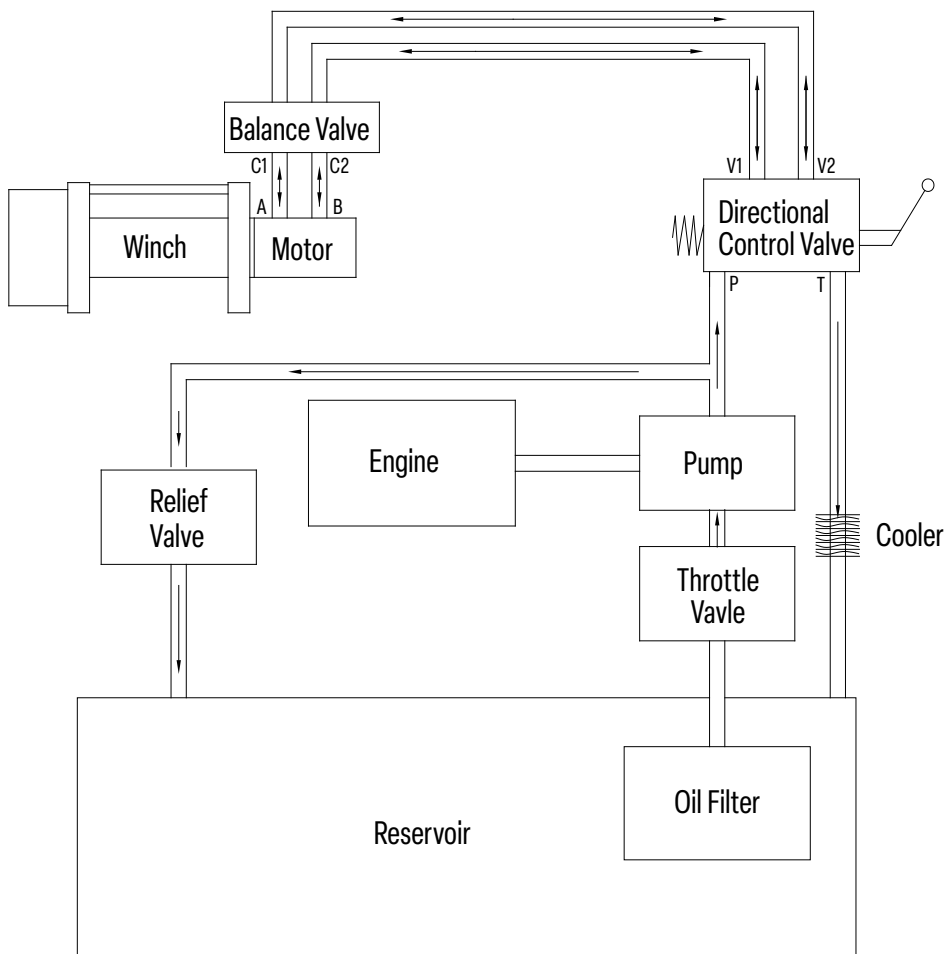
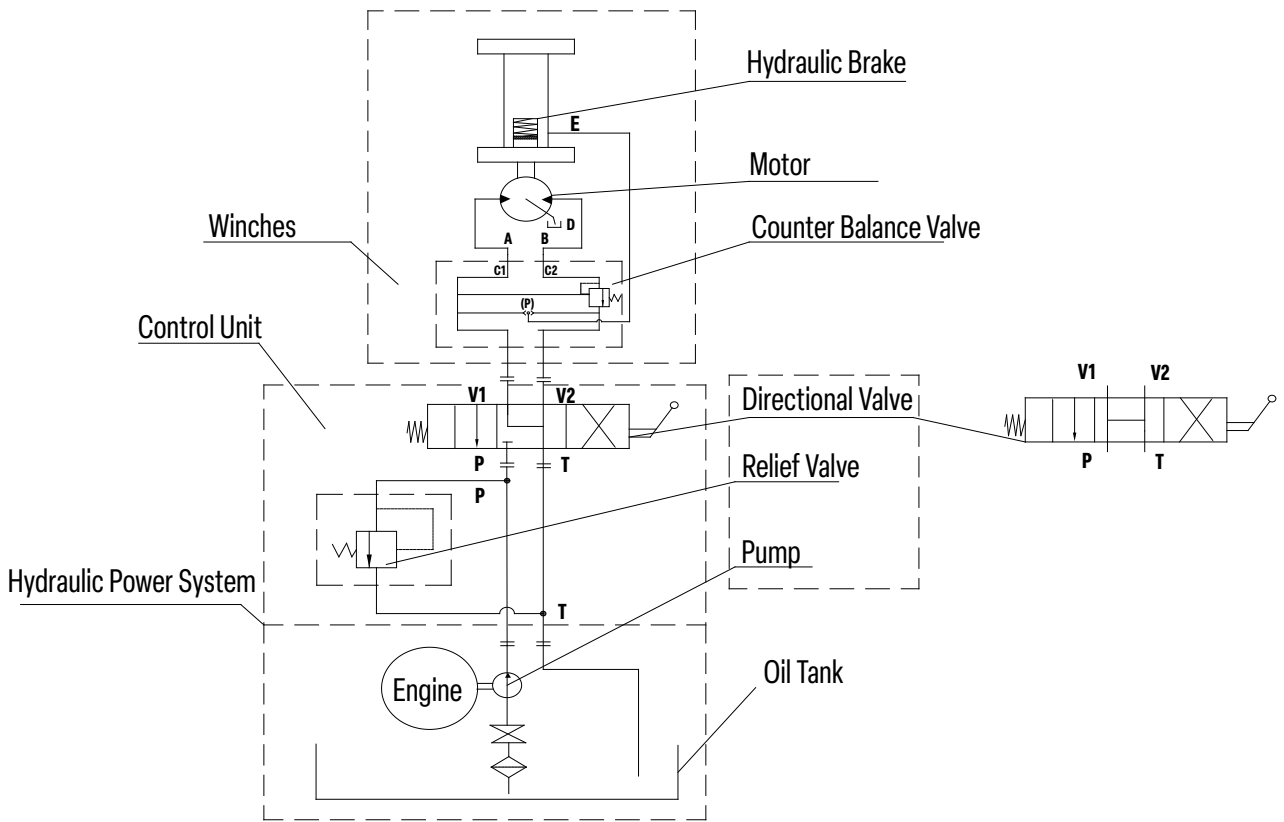

AIR CLUTCH OPERATION

Air clutch for free spool

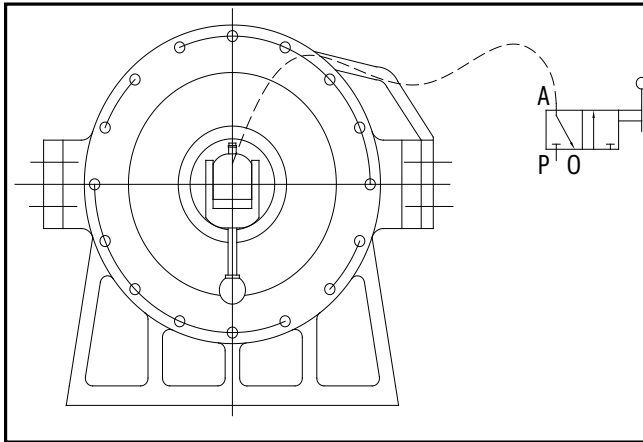

Air clutch for free spool and two speed

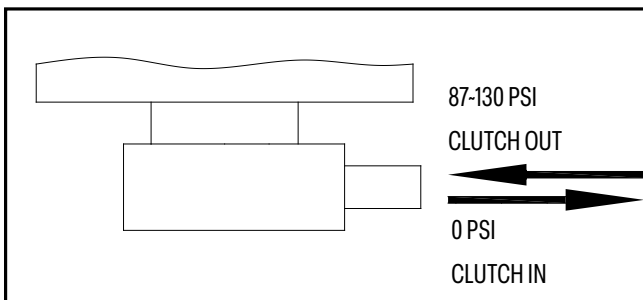
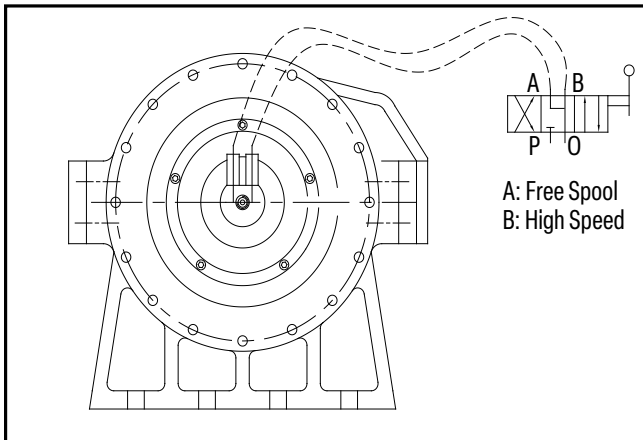

⚠ DANGER

These winches are not designed to be installed on 4x4, or any off-road vehicle, by doing so will void your warranty.

The hydraulic system needs a relief valve to ensure the system safety. The absence of such a valve could cause serious damage the winch and(or) serious injury or death.

If you are using a heat exchanger with your application to cool the hydraulic fluid, you should refer to the illustration about mounting.

You should check the hydraulic fluid level regular and replace any that may have seeped or spilled out. The hydraulic system should be purged at this time. Listed below are the directions on how to purge the hydraulic system.

Purging the hydraulic system.

1. Start the engine.
2. Power the winch to draw out about 5 feet of cable.
3. Shut down the engine.
4. Check the fluid level and fill as needed.
5. Repeat steps 1 through 4 as necessary.
6. Start the engine.
7. Move the cable into the desired position.
8. Turn the wheels on the vehicle from the right lock to the left lock positions five times to help bleed the hydraulic system.

⚠ WARNING

- Clutch is in all the time, for clutch out, pressure 87-130psi is required into winch
- Pressure should not be below 87psi, otherwise clutch will not work
- When winch is under load or spooling, NEVER turn the clutch to out.

MAINTENANCE PRECAUTIONS

1. Correct use of the hydraulic winch can effectively increase the life of the winch by many years.
2. We strongly recommend spring washers are used with mounting bolts. Mounting bolts and wire rope must be inspected for looseness regularly, if found to be loose always tighten before using the winch.
3. Re-spooling or changing the wire rope: Using the selector valve, spool the drum into a suitable position, remove or feed the wire rope into the hole on the edge of the drum. Insert steel plate and screws and tighten. Start the winch, using minimum load spool in the wire rope making it neat and tidy.
4. Pay attention to the wire ropes orientation on the drum reel. If the rope is kinked, frayed or damaged in any way it MUST be replaced immediately with a OEM part, if not replaced with an original this will void any warranty.
5. During normal working, the pulling force must be equal or less than the rated capacity. Overloading the winch capacity, is not allowed. The maximum pulling force of the winch, is around 1.25 times of its rated capacity, if exceeded will cause damage to the winch and(or) equipment or serious injury. By doing so will void any warranty.
6. The opening pressure of the balancing valve must be 0.1-0.4Mpa higher than the brake, or the winch will shake when lowering it down. Our company has tested hoisting and adjusted balancing valves for every winch before it leaves the factory. Therefore, there is no need for users/operator to adjust it at all, But if there are special cases where the users need to adjust it, the users can spiral the adjusting screw outward, thus making the opening pressure higher, Never try to adjust the balance valve yourself use a specialist person or service agent.
7. If there is an abnormal pressure increase in the system, the users must stop using the winch immediately. Check if there is leakage of the oil, and if the hydraulic motor is normal. Usually, when hydraulic motor works under the load, the leaked oil from the pipe must not surpass 1m/m. Plenty of leakage demonstrates a damaged hydraulic motor, which must be repaired or replaced immediately. Or, if the hydraulic motor is in good condition, check other parts inside the system.
8. Check the operation of the hydraulic winch and its systems regularly during the work or weekly. In case of abnormal temperature rise, leakage, abnormal noise and vibration or pressure fluctuation, the user should stop the winch immediately to check the causes and overhaul it.
9. Pay attention to the tank's oil and its level. If there is much foam, the users should stop immediately to check whether air leaks from the oil inlet of hydraulic system, the return oil port below the water, and whether hydraulic oil is emulsified by the entrance of the water.
10. If the winch is showing signs of degraded performance change the hydraulic oil. Do Not mix old and new oil always replace all.
11. Put 90 # gear oil into the winch speed reducer before using it and replace the oil after 100 accumulated working hours. First remove the screw plugs on the drum, then slowly roll the drum to make drum block hole aim at the block hole on the planetary gear reducer. Carefully take the plug out with an Allen Key. Drain all the used oil and add the new oil. Tighten each and every plug.
12. Regularly check the oil filter, which should be cleaned and replaced regularly.
13. Standing under the winch hook is strictly prohibited.

Overhaul

When the hydraulic winch doesn't work or has malfunctioned is confirmed, the operator/user can check and repair if qualified to do so. In instances where user is not able to do this, then do not dismantle or repair. Contact a professional repair specialist to overhaul. Be careful when dismantling this hydraulic winch that you don't make scratches or indentations on precision parts, especially to surfaces of moving and seal parts. Repair or replace damaged parts immediately. Before assembling, all parts must be cleaned, and coated with lithium grease (If applicable)

Lifting

These winches are not recommended to be used for lifting, if you use your winch for hoisting (lifting) then you need to implement a safety factor 5:1. Ensure when using for lifting there is a minimum of 1 layer on the drum at any time and pay attention to fixations and drum capacity.

Storage

The Hydraulic winch should be stored in the warehouse where the air is dry and no corrosive gas. Do not put it under high temperature 50°C or at a -20°C environment for long-term storage, in case the aging of sealing parts are accelerated.

If the Hydraulic winch is in a long-term storage, the user should drain all the oil from it, and fill the machine fully with Turbine Oil with a low acid value.

TROUBLESHOOTING

Problem	Cause	Solution
Winch does not does not turn	Insufficiently hydraulic system pressure.	Check relief valve regulate pressure.
	Improper connections of hydraulic system, no oil into motor.	Check all the plumbing fixtures according to the working principle chart.
		Defective directional control valve.
Motor runs but drum does not turn	Clutch not engaged	Turn clutch to the High or Low speed position. If problem persists, ask a technician to check and repair.
Motor runs slowly or without normal power	Insufficient pressure or oil flow	Bump is not suitable or defective. Change a new one or a suitable one
	Insufficient fluid in the system	Check fluid level. Add fluid until full.
	Wrong winch working direction.	Change the connection of balance valve and motor.
Winch cannot spool off wire rope with load smoothly.	Wrong winch working direction.	Change the connection of balance valve and motor.

WARRANTY*

BPE Limited Ltd are the sole distributors of these WARRIOR WINCHES and associated brands/equipment.

BPE Limited (“seller” or BPE) warrants to the original retail buyer only (“Buyer”) that any mechanical component of this genuine winch (“product(s)”) are free of defects in material and workmanship for the lifetime of the winch.

The electrical components (including the motor, contactor, and switches) will be free of defects in material and workmanship for a period of (3) three years (36 Months) from the original purchase provable date of purchase

Any product BPE Limited determines to be defective will be repaired or replaced at our (BPE Limited) sole discretion without charge to the Buyer upon Buyer’s compliance with this procedure. Seller or its Authorized Agent may make reasonable charges for parts and(or) labour for repairs not covered by this Lifetime Limited Warranty. None warrantable returns will be charged at BPE Limited standard rates. The warranties set forth herein are exclusive and in lieu of all other warranties, whether oral or written, express or implied.

If in the event your product becomes faulty within your warranty period

To obtain service or repair under this warranty, the Buyer shall mail, ship or otherwise deliver to the manufacturers address, at the Buyers expense; (1) the Product, (2) a written description of the problem, (3) Buyers name, address and contact number, (4) copy of the original purchase receipt or BPE Limited can arrange a suitable collection method (Charges apply).

Warranty Exclusions

The Warranty does not cover the cost of labour or transportation/shipping charges for the replacement or installation of defective part(s).

This warranty does not apply to defects of the Product caused by; (1) normal wear and tear, (2) failure to comply with any installation, maintenance or subjecting the product to loads in excess of the loads written/listed in the owners manual or as detailed upon the Sellers website, (3) alteration or modification by any parties other than the manufacturer, (4) misuse, abuse, neglect, accidents, Acts of God, terrorism or (5) failure to correctly use the item according to the owners manual (7) other causes beyond the control of the Seller after delivery of the Product to the Sellers Authorized Agent.

Other Exclusions

This Warranty does not cover steel cables, synthetic ropes, fairleads, wireless remotes or any exterior finishes outside thirty (30) Days from purchase.

BPE Limited shall not be responsible or liable for any indirect or consequential damages. These consequential damages may include, but are not limited to, lost profits or loss of use, down time or damage to other person(s) equipment.

BPE Limited reserves the right to change the Product design without notice. BPE Limited reserves the right to replace any part or whole unit with a newer design of the same function.

SPECIFICATIONS 10JP

Rated line pull Lbs (Kg)	22000 LBS (10000 kgs)
Wire Rope Capacity	158 FT [48 m]
Wire Rope	Ø15 mm, Optional Item
Design Standard	ISO 4301 & SAE J706
Hydraulic Motor	Sauer Danfoss OMS 100
Hydraulic Operating Pressure	2900 PSI (20Mpa)
Free Spooling Clutch	Pneumatic
Pneumatic Clutch Pressure	0.4 - 0.8 MPa
Rope Pressing Device	Standard Item
Rope Roller Fairlead	Optional Item
Oil	Industrial Gear Oil 220
Oil Capacity	0.2 Gallon [0.8 Liter]
Mounting Bolts	8-M14
Mounting bolt pattern	17.0 "×2.5 " ×7.6 " (431mm×64mm×192mm)
Cable (Dia.× L)	Ø19/32"×157 ' (Ø15mm×48m)
Drum size (Dia.× L)	Ø5.4 "×12.4" (Ø138mm×316mm)
Overall dimensions (L×W×H)	32.7"×15.4"×12.6" 830mm ×390mm ×320mm
Gross Weight LBS (KG)	363.8 (165)

Pull , Speed, Pressure, Flow (First layer)

Line pull lbs (kgs)	Pressure Mpa(Psi)	Flow G/min (L/min)	Line speed ft/min(m/min)
0	2.5(362.6)	4.0(15)	26.9(8.2)
4000(1814)	4.2(609.1)	7.9(30)	23.6(7.2)
8000(3629)	8.5(1232.8)	13.2(50)	19.7(6.0)
15000(6804)	14.0(2030.5)	15.9(60)	11.8(3.6)
22000(9979)	20(2900.7)	19.9(75)	5.9(1.8)

Line pull, cable capacity and the line speed per layer

Layer of wire rope	Rated line pull lbs(kgs)	Total rope on drum ft (m)
1	22000 (10000)	33.8(10.3)
2	18393(8343)	73.8(22.5)
3	15802(7168)	117.8(35.9)
4	13852(6283)	157.5(48.0)

WINCH ASSEMBLY DRAWING 10JP

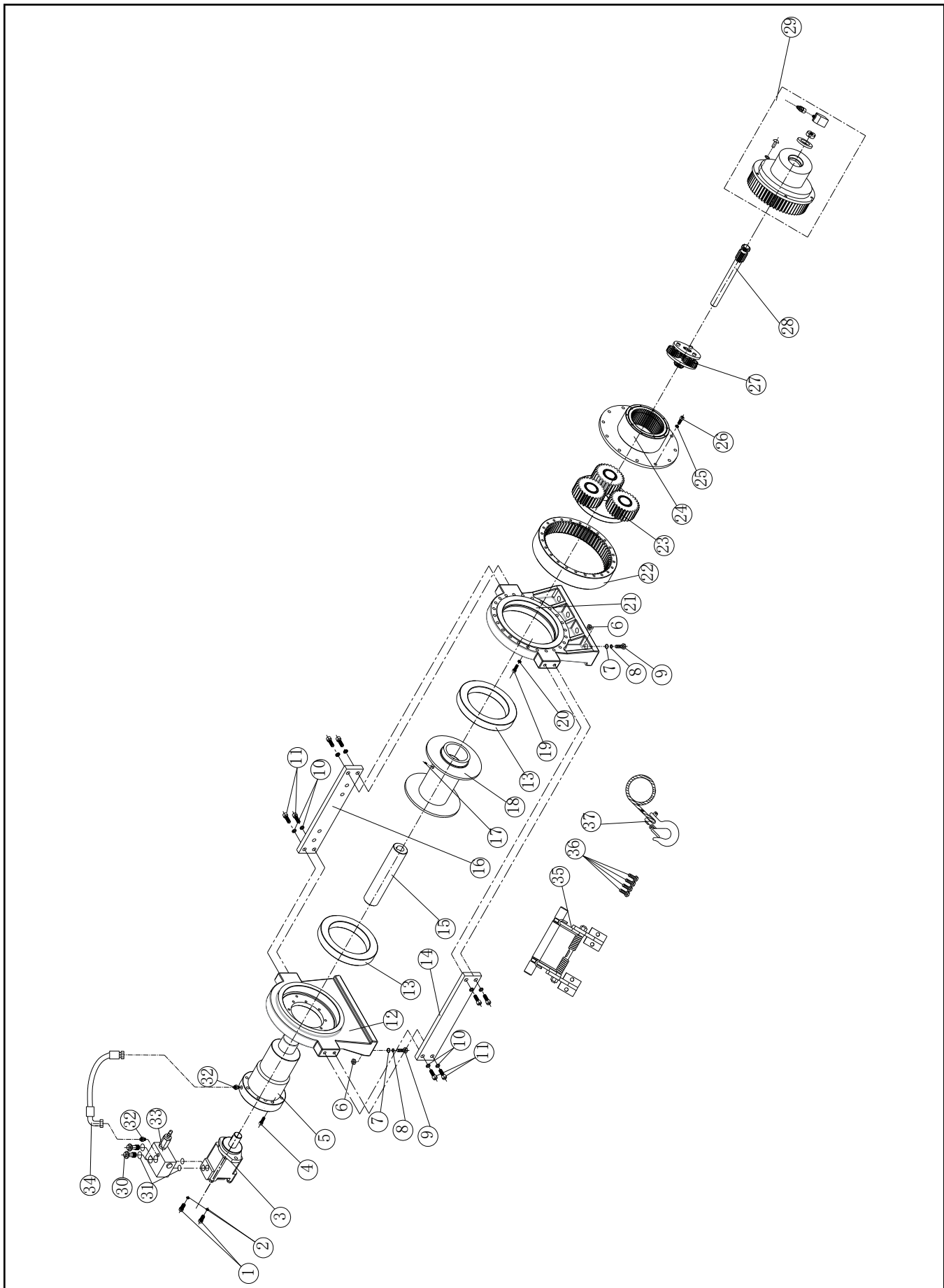

WINCH PARTS LIST (10JP)

#	Part Number	Description	Qty.
1	C220NH0001	Screw M12 x 35	2
2	C220NH0002	Lock Washer Ø12	2
3	C220NH010	Hydraulic Motor	1
4	C220NH0003	Screw M8 x 30	8
5	C220NH0200	Break / Shaft Assembly	1
6	C220NH0004	Hex Flange Nut M14	8
7	C220NH0005	Thin Flat Washer Ø14	8
8	C220NH0006	Lock Washer Ø14	8
9	C220NH0007	Cap Screw M14 x 50	8
10	C220NH0008	Lock Washer Ø10	8
11	C220NH0009	Screw M10 x 30	8
12	C220NH0010	Front Bearing	1
13	C220NH0011	Roller Bearing	2
14	C220NH0012	Frontal Mounting Plate	1
15	C220NH0013	Coupling	1
16	C220NH0014	Back Mounting Plate	1
17	C220NH0015	Screw M8 x 10	1
18	C220NH0300	Drum Assembly	1
19	C220NH0016	Screw M8 x 35	24
20	C220NH0017	Lock Washer Ø8	24
21	C220NH0018	End Bearing	1
22	C220NH0019	Gear-Ring	1
23	C220NH0400	Gear Carrier Assembly (Output)	1
24	C220NH0500	Cam Gear (Input)	1
25	C220NH0017	Lock Washer Ø8	12
26	C220NH0020	Screw M8 x 20	12
27	C220NH0600	Gear Carrier Assembly (Input)	1
28	C220NH0021	Transmission Shaft	1
29	C220NH0700	Clutch Assembly	1
30	C220NH0022	Screw	2
31	C220NH023	Seal Ring	4
32	C220NH0800	Tube Fittings Assembly	2
33	C220NH0900	Balanced Valve Assembly	1
34	C220NH1000	Plumbing Fixtures	1
35	C220NH1100	Tensioned Of Steel Wire Supplied Assembly	1
36	C220NH0024	Screw M10 x 25	4

#	Part Number	Description	Qty.
37	C220NH1200	Cable Assembly	1

WINCH ASSEMBLY DRAWING 13JP

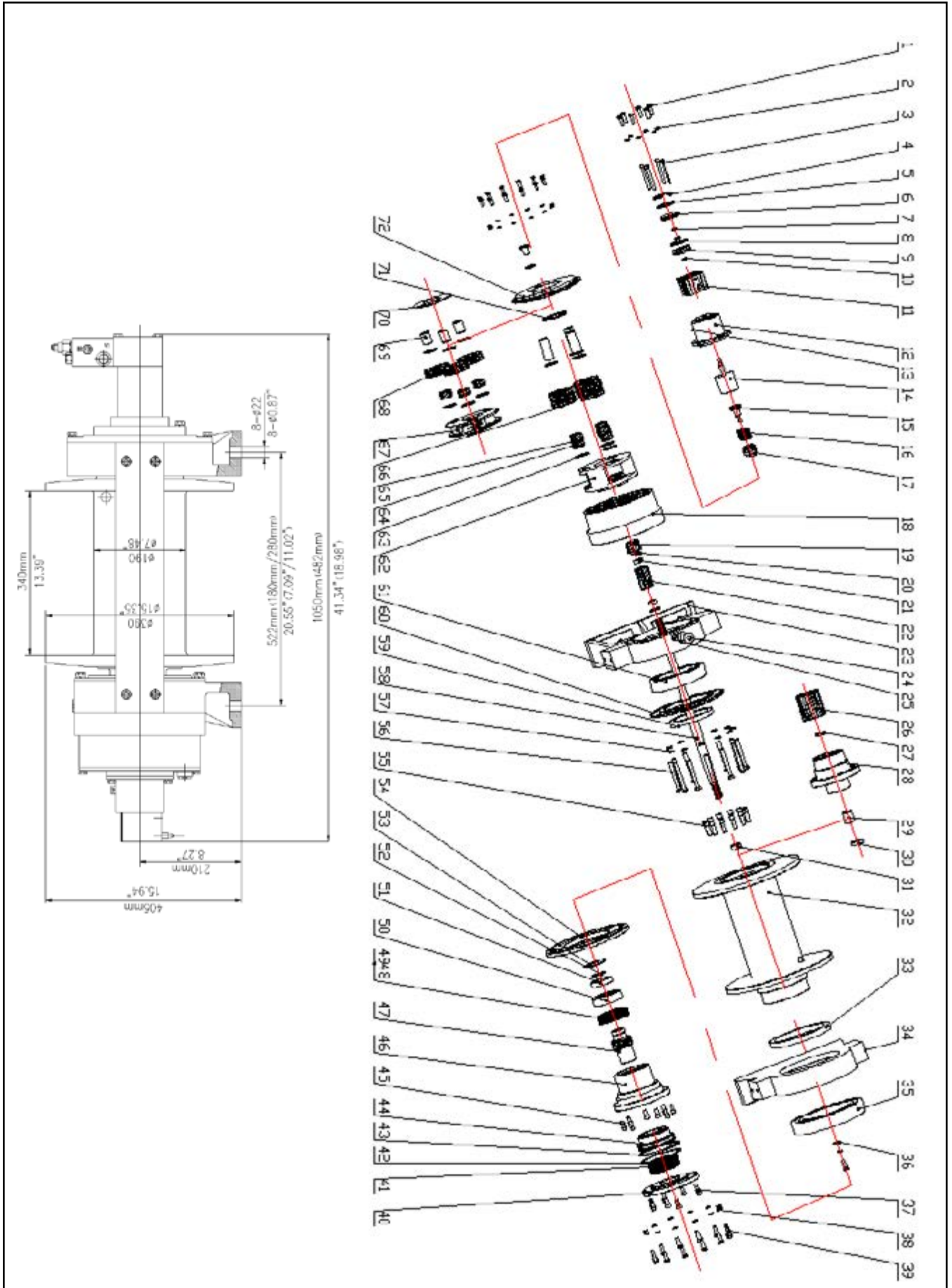

WINCH PARTS LIST (13JP)

#	Part Number	Description	Qty.
1	GB5783-86	Bolt M8*20	6
2	GB93-87	Gasket 8	6
3	GB70.1-2000	Screw M12*55	4
4	GB893.1-86	check ring 65	1
5	GB3452.1-2005	O-ring 58*2.65	2
6	IYJ100.1-1	Cylinder cover	1
7	GB/T6172.1-2000	Nut M10	2
8	GB3452.1-2005	O-ring 58*2.65	2
9	IYJ100.1-2	Bib	1
10	GB3452.1-2005	O-ring 58*2.65	1
11	IYJ100.1-9B	Cylinder liner	1
12	IYJ100.1-8	Air vat	1
13	IYJ100A.4-2	Screw	1
14	IYJ100A.4-1	Fork	1
15	IYJ100.1-5	Spring seat	1
16	IYJ100.1-4	Spring	1
17	IYJ100A.4-3	linker	1
18	IYJ100A-2	Gear ring	1
19	IYJ100A-14	First stage sun gear	1
20	IYJ100A-12	Cover	2
21	IYJ100A.1-8	Cover	2
22	IYJ100A.1-7	Second stage sun gear	1
23	IYJ100A-10	The left bearing	1
24	JB1001-77	Ventilate plug screw	2
25	JB982-77	Gasket 20	2
26	IYJ100A-11	Driver axle	1
27	IYJ100A-12	Gasket	1
28	IYJ100A-11	The middle axle	1
29	IYJ100A-7	Gasket	1
30	GB3452.1-85	Oil seal 32x52x8	1
31	IYJ100A-12	Gasket	1
32	IYJ100A-4	Drum	1
33	GB9877.1-86	Oil seal 200*230*15	1
34	IYJ100A-5	The right bearing	1
35	GB276-89	Bring 61938	1
36	IYJ100A-7	Gasket	1
37	GB70-85	Screw M10*20	8

#	Part Number	Description	Qty.
38	GB93-87	Gasket 10	13
39	GB5783-86	Bolt M10*30	13
40	IYJ100A.3-4	Motor seat	1
41	Z30A-16	Spring	16
42	GB3452.1-86	check ring A124*136*2	1
43	GB3452.1-86	O-ring 120*7	1
44	IHK3B21E.1-2	Bib	1
45	GB70-85	Screw M10*30	12
46	IYJ100A.3-2	Brake cage	1
47	IYJ100A.3-3	Splined hub	1
48	HS70K-11	Inner friction disc	6
49	HS70K-10A	outside friction disc	7
50	IYJ100A.3-5	Bring seat	1
51	GB276-89	Bring 61916	1
52	GB893.1-86	check ring 75	1
53	JB/ZQ4341-1997	check ring 102*4	1
54	IYJ100A.3-1	Cover	1
55	GB70-85	Screw M12*45	20
56	GB5782-86	Bolt M12*100	12
57	GB93-87	Gasket 12	12
58	IYJ100A-6	Driver axle	1
59	GB9877.1-86	Oil seal 130*160*12	1
60	IYJ100A-3	Driver axle	1
61	GB288-87	Bring 3053124	1
62	IYJ100A.1-2	Second stage planet carrier	1
63	IYJ100A.1-4	First stage planet gasket	12
64	GB309-84	Roller 5*21.8	252
65	IYJ100A-9	Gasket	3
66	IYJ100A.2-3	Second stage planet gear	3
67	IYJ100A.1-6	First stage planet carrier	1
68	IYJ100A.1-3	First stage planet gear	3
69	IYJ100A.1-2	First stage planet axle	3
70	IYJ100A.1-1	Gasket	1
71	IYJ100A-13	Gasket	1
72	IYJ100A-1	Cover	1

SPECIFICATIONS 13JP

Rated line pull Lbs (Kg)	29700 LBS (13500KG)
Rated Torque	12500 LBF-FT [17000 Nm]
Wire Rope Capacity	160 FT [50 m]
Wire Rope	Ø18 mm, Optional Item
Design Standard	ISO 4301 & SAE J706
Hydraulic Motor	Sauer Danfoss OMS 200
Hydraulic Operating Pressure	2465 PSI [17 MPa]
Free Spooling Clutch	Pneumatic
Pneumatic Clutch Pressure	0.4 - 0.8 MPa
Rope Pressing Device	Standard Item
Rope Roller Fairlead	Optional Item
Oil	Industrial Gear Oil 220
Oil Capacity	0.2 Gallon [0.8 Liter]
Mounting Bolts	8×M20, Class 10.9
Mounting bolt pattern	20.55"×7.09/11.02" 8- Ø0.87 " 522mm ×180/280mm 8- Ø22
Cable (Dia.× L)	Ø0.71 "×160 FT(Ø20mm×40m)
Drum size (Dia.× L)	Ø7.48 "×13.39 " (Ø190mm×340 mm)
Overall dimensions (L×W×H)	41.34"×25.20 "×15.94 " 1050mm ×640mm ×405mm
Weight	597 LBS (271 kg)

Line Pull And Line Speed In Layer

Layer	Rated Line Pull Per Layer	Maximum Line Speed Per Layer
1	29700 LBS (13500KG)	17 FPM [5.17 m/min]
2	25700 LBS [11600KG]	19.36 FPM [5.9 m/min]
3	22700 LBS [10300KG]	22.05 FPM [6.72 m/min]
4	20500 LBS [9200KG]	24.61 FPM [7.50 m/min]
5	18500 LBS [83000KG]	27.17 FPM [8.28 m/min]

SPECIFICATIONS 15JP

Rated line pull Lbs (Kg)	33000 LBS (15000KG)
Rated Torque	11000 LBF-FT[15000 Nm]
Wire Rope Capacity	160 FT [50 m]
Wire Rope	Ø22 mm, Optional Item
Design Standard	ISO 4301 & SAE J706
Hydraulic Motor	Sauer Danfoss OMS 245
Hydraulic Operating Pressure	2320 PSI [16 MPa]
Free Spooling Clutch	Pneumatic
Pneumatic Clutch Pressure	0.4 - 0.8 MPa
Air Rope Tensioner	Standard Item
Rope Roller Fairlead	Optional Item
Oil	Industrial Gear Oil 220
Oil Capacity	0.2 Gallon [0.8 Liter]
Mounting Bolts	8×M20, Class 10.9
Mounting bolt pattern	20.55"×7.09/11.02" 8- Ø0.87 " 522mm×180/280mm 8- Ø22
Cable (Dia.× L)	Ø0.87 "×160 FT(Ø22mm×50m)
Drum size (Dia.× L)	Ø8.27 "×13.4 " (Ø210mm×340 mm)
Overall dimensions (L×W×H)	42.4"×25.20 "×16.54 " 1077mm×640mm×420mm
Weight	705 LBS [320 kg]

Line Pull And Line Speed In Layer

Layer	Rated Line Pull Per Layer	Maximum Line Speed Per Layer
1	33000 LBS (15000KG)	26.8 FPM [8.17 m/min]
2	28000 LBS [12700KG]	31 FPM [9.45 m/min]
3	24500 LBS [11100KG]	35.6 FPM [10.85 m/min]
4	21000 LBS [95000KG]	40 FPM [12.19 m/min]
5	19000 LBS [8500KG]	44.5 FPM [13.56 m/min]

WINCH ASSEMBLY DRAWING 15JP

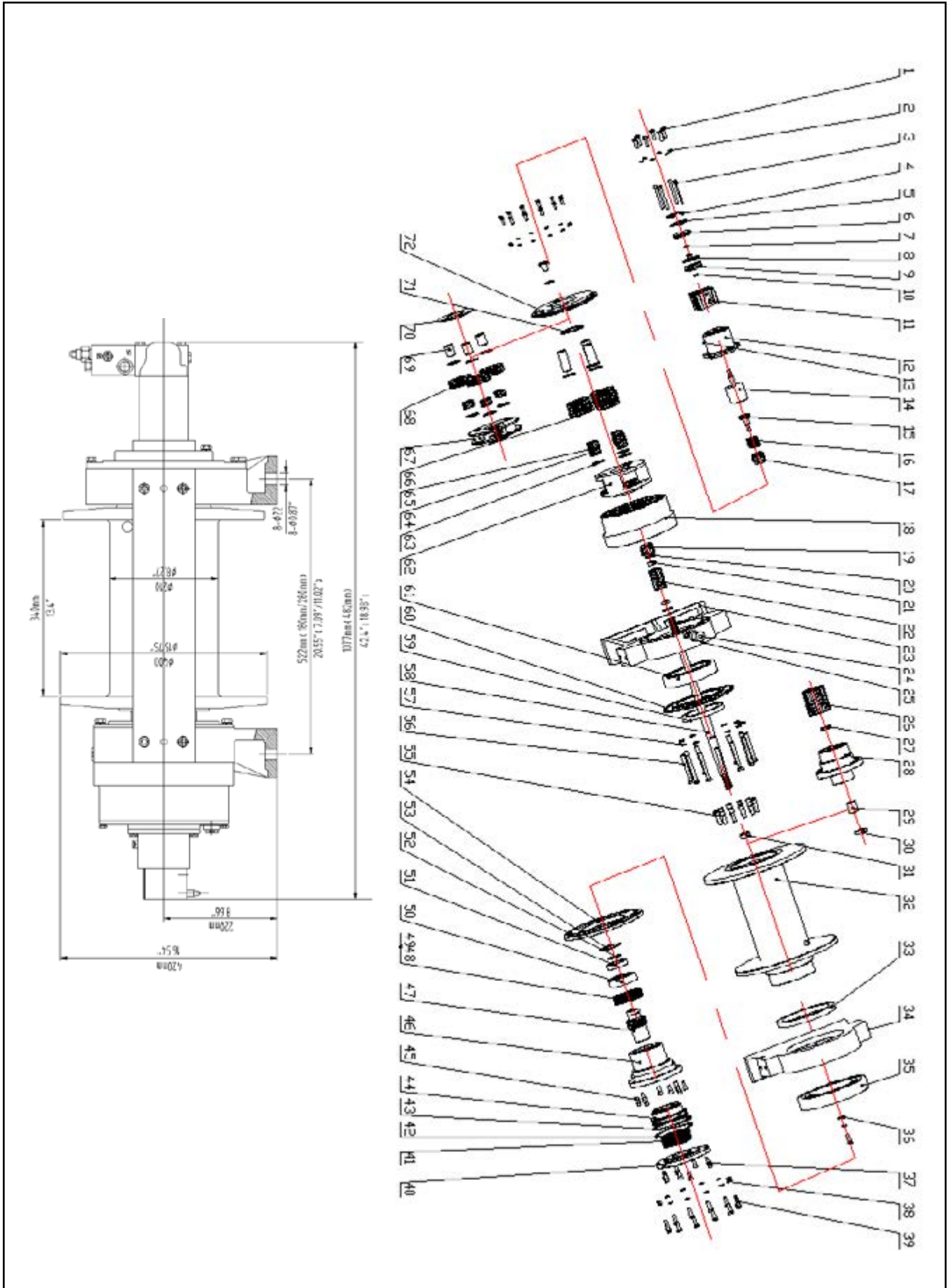

WINCH PARTS LIST (15JP)

#	Part Number	Description	Qty.
1	GB5783-86	Bolt M8*20	6
2	GB93-87	Gasket 8	6
3	GB70.1-2000	Screw M12*55	4
4	GB893.1-86	check ring 65	1
5	GB3452.1-2005	O-ring 58*2.65	2
6	IYJ100.1-1	Cylinder cover	1
7	GB/T6172.1-2000	Nut M10	2
8	GB3452.1-2005	O-ring 58*2.65	2
9	IYJ100.1-2	Bib	1
10	GB3452.1-2005	O-ring 58*2.65	1
11	IYJ100.1-9B	Cylinder liner	1
12	IYJ100.1-8	Air vat	1
13	IYJ150.4-2	Screw	1
14	IYJ150.4-1	Fork	1
15	IYJ100.1-5	Spring seat	1
16	IYJ100.1-4	Spring	1
17	IYJ150.4-3	linker	1
18	IYJ150-2	Gear ring	1
19	IYJ150-14	First stage sun gear	1
20	IYJ150-12	Cover	2
21	IYJ150.1-8	Cover	2
22	IYJ150.1-7	Second stage sun gear	1
23	IYJ150-10	The left bearing	1
24	JB1001-77	Ventilate plug screw	2
25	JB982-77	Gasket 20	2
26	IYJ150-11	Driver axle	1
27	IYJ150-12	Gasket	1
28	IYJ150-11	The middle axle	1
29	IYJ150-7	Gasket	1
30	GB3452.1-85	Oil seal 32x52x8	1
31	IYJ150-12	Gasket	1
32	IYJ150-4	Drum	1
33	GB9877.1-86	Oil seal 200*230*15	1
34	IYJ150-5	The right bearing	1
35	GB276-89	Bring 61938	1
36	IYJ150-7	Gasket	1
37	GB70-85	Screw M10*20	8

#	Part Number	Description	Qty.
38	GB93-87	Gasket 10	13
39	GB5783-86	Bolt M10*30	13
40	IYJ150.3-4	Motor seat	1
41	Z30A-16	Spring	16
42	GB3452.1-86	check ring A124*136*2	1
43	GB3452.1-86	O-ring 120*7	1
44	IHK3B21E.1-2	Bib	1
45	GB70-85	Screw M10*30	12
46	IYJ150.3-2	Brake cage	1
47	IYJ150.3-3	Splined hub	1
48	HS70K-11	Inner friction disc	6
49	HS70K-10A	outside friction disc	7
50	IYJ150.3-5	Bring seat	1
51	GB276-89	Bring 61916	1
52	GB893.1-86	check ring 75	1
53	JB/ZQ4341-1997	check ring 102*4	1
54	IYJ150.3-1	Cover	1
55	GB70-85	Screw M12*45	20
56	GB5782-86	Bolt M12*100	12
57	GB93-87	Gasket 12	12
58	IYJ150-6	Driver axle	1
59	GB9877.1-86	Oil seal 130*160*12	1
60	IYJ150-3	Driver axle	1
61	GB288-87	Bring 3053124	1
62	IYJ150.1-2	Second stage planet carrier	1
63	IYJ150.1-4	First stage planet gasket	12
64	GB309-84	Roller 5*21.8	252
65	IYJ150-9	Gasket	3
66	IYJ150.2-3	Second stage planet gear	3
67	IYJ150.1-6	First stage planet carrier	1
68	IYJ150.1-3	First stage planet gear	3
69	IYJ150.1-2	First stage planet axle	3
70	IYJ150.1-1	Gasket	1
71	IYJ150-13	Gasket	1
72	IYJ150-1	Cover	1

WINCH ASSEMBLY DRAWING 20JP

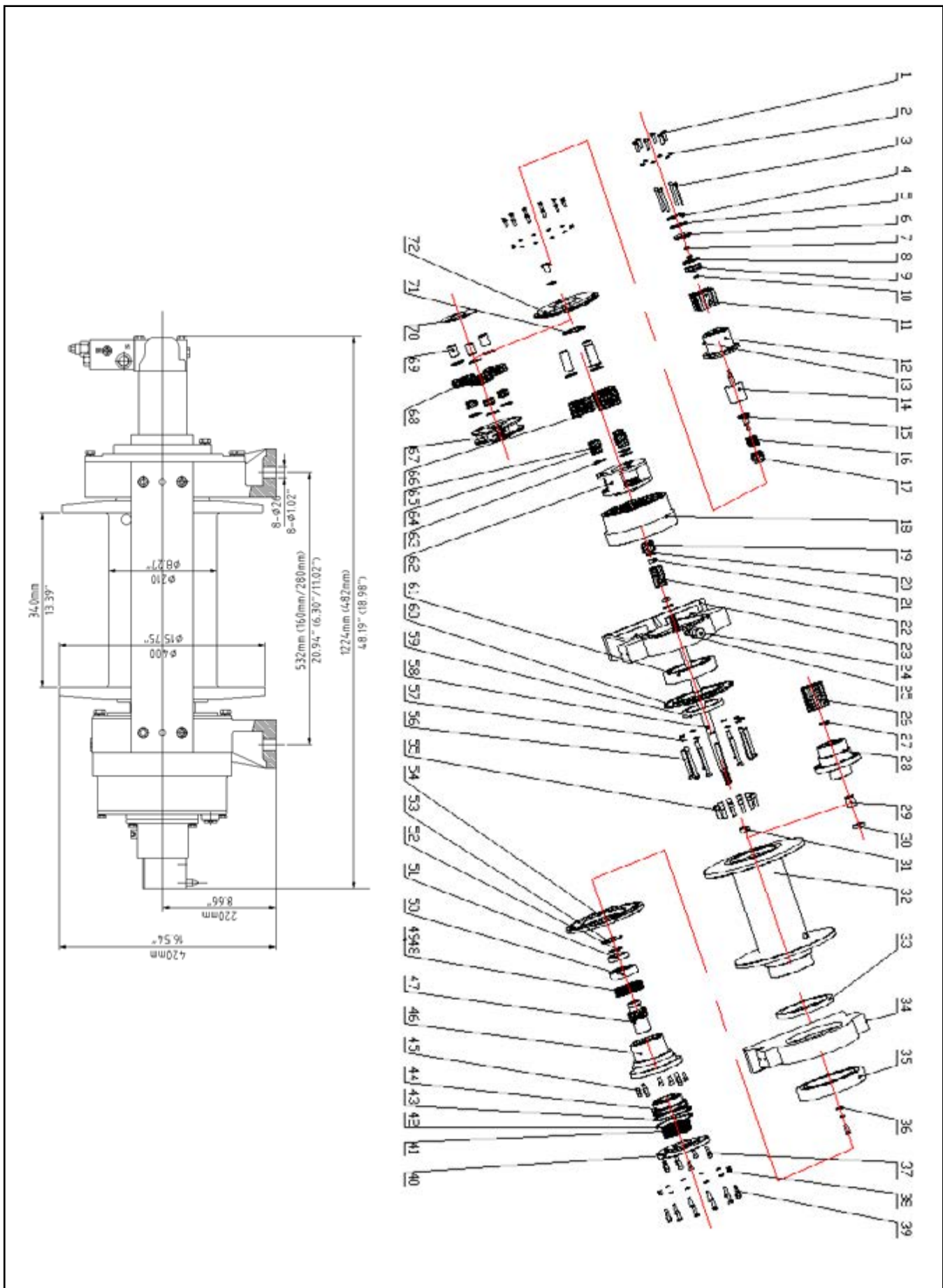

WINCH PARTS LIST (20JP)

#	Part Number	Description	Qty.
1	GB5783-86	Bolt M8*20	6
2	GB93-87	Gasket 8	6
3	GB70.1-2000	Screw M12*55	4
4	GB893.1-86	check ring 65	1
5	GB3452.1-2005	O-ring 58*2.65	2
6	IYJ100.1-1	Cylinder cover	1
7	GB/T6172.1-2000	Nut M10	2
8	GB3452.1-2005	O-ring 58*2.65	2
9	IYJ100.1-2	Bib	1
10	GB3452.1-2005	O-ring 58*2.65	1
11	IYJ100.1-9B	Cylinder liner	1
12	IYJ100.1-8	Air vat	1
13	IYJ150.4-2	Screw	1
14	IYJ150.4-1	Fork	1
15	IYJ100.1-5	Spring seat	1
16	IYJ100.1-4	Spring	1
17	IYJ200.4-3	linker	1
18	IYJ200-2	Gear ring	1
19	IYJ200-14	First stage sun gear	1
20	IYJ200-12	Cover	2
21	IYJ200.1-8	Cover	2
22	IYJ200.1-7	Second stage sun gear	1
23	IYJ200-10	The left bearing	1
24	JB1001-77	Ventilate plug screw	2
25	JB982-77	Gasket 20	2
26	IYJ200-11	Driver axle	1
27	IYJ150-12	Gasket	1
28	IYJ150-11	The middle axle	1
29	IYJ200-7	Gasket	1
30	GB3452.1-85	Oil seal 32x52x8	1
31	IYJ200-12	Gasket	1
32	IYJ200-4	Drum	1
33	GB9877.1-86	Oil seal 200*230*15	1
34	IYJ200-5	The right bearing	1
35	GB276-89	Bring 61938	1
36	IYJ150-7	Gasket	1
37	GB70-85	Screw M10*20	8

#	Part Number	Description	Qty.
38	GB93-87	Gasket 10	13
39	GB5783-86	Bolt M10*30	13
40	IYJ200.3-4	Motor seat	1
41	Z30A-16	Spring	16
42	GB3452.1-86	check ring A124*136*2	1
43	GB3452.1-86	O-ring 120*7	1
44	IHK3B21E.1-2	Bib	1
45	GB70-85	Screw M10*30	12
46	IYJ200.3-2	Brake cage	1
47	IYJ200.3-3	Splined hub	1
48	HS70K-11	Inner friction disc	6
49	HS70K-10A	outside friction disc	7
50	IYJ200.3-5	Bring seat	1
51	GB276-89	Bring 61916	1
52	GB893.1-86	check ring 75	1
53	JB/ZQ4341-1997	check ring 102*4	1
54	IYJ200.3-1	Cover	1
55	GB70-85	Screw M12*45	20
56	GB5782-86	Bolt M12*100	12
57	GB93-87	Gasket 12	12
58	IYJ200-6	Driver axle	1
59	GB9877.1-86	Oil seal 130*160*12	1
60	IYJ200-3	Driver axle	1
61	GB288-87	Bring 3053124	1
62	IYJ200.1-2	Second stage planet carrier	1
63	IYJ200.1-4	First stage planet gasket	12
64	GB309-84	Roller 5*21.8	252
65	IYJ200-9	Gasket	3
66	IYJ200.2-3	Second stage planet gear	3
67	IYJ200.1-6	First stage planet carrier	1
68	IYJ200.1-3	First stage planet gear	3
69	IYJ200.1-2	First stage planet axle	3
70	IYJ200.1-1	Gasket	1
71	IYJ200-13	Gasket	1
72	IYJ200-1	Cover	1

SPECIFICATIONS 20JP

Rated line pull Lbs (Kg)	44000 LBS (20000KG)
Rated Torque	16500 LBF-FT [22371 Nm]
Wire Rope Capacity	160 FT [50 m]
Wire Rope	Ø26 mm, Optional Item
Design Standard	ISO 4301 & SAE J706
Hydraulic Motor	Sauer Danfoss OMT 310
Hydraulic Operating Pressure	2465 PSI [17 MPa]
Free Spooling Clutch	Pneumatic
Pneumatic Clutch Pressure	0.4 - 0.8 MPa
Air Rope Tensioner	Standard Item
Rope Roller Fairlead	Optional Item
Oil	Industrial Gear Oil 220
Oil Capacity	0.2 Gallon [0.8 Liter]
Mounting Bolts	8×M24, Class 10.9
Mounting bolt pattern	20.94"×6.30/11.02" 8- Ø1.02 " 532mm×160/280mm 8- Ø26
Cable (Dia.× L)	Ø1.02 "×160 FT(Ø26mm×45m)
Drum size (Dia.× L)	Ø8.27 "×13.39 " (Ø210mm×340 mm)
Overall dimensions (L×W×H)	48.19"×25.20"×16.54 " 1224mm×640mm×420mm
Gross Weight	815 LBS [370 kg]

Line Pull And Line Speed In Layer

Layer	Rated Line Pull Per Layer	Maximum Line Speed Per Layer
1	44000 LBS (20000KG)	23 FPM [7.01 m/min]
2	36000 LBS [16000 KG]	27.4 FPM [8.35 m/min]
3	31000 LBS [14000 KG]	31.78 FPM [9.69 m/min]
4	27000 LBS [12200 KG]	36.17 FPM [11.02 m/min]
5	24000 LBS [10800 KG]	40.57 FPM [12.37 m/min]

SPECIFICATIONS 25JP

Rated line pull Lbs (Kg)	55000 LBS (25000KG)
Rated Torque	25000 LBF-FT [34000 Nm]
Wire Rope Capacity	180 FT [55 m]
Wire Rope	Ø30 mm, Optional Item
Design Standard	ISO 4301 & SAE J706
Hydraulic Motor	Sauer Danfoss OMT 310
Hydraulic Operating Pressure	2610 PSI [18 MPa]
Free Spooling Clutch	Pneumatic
Pneumatic Clutch Pressure	0.4 - 0.8 MPa
Air Rope Tensioner	Pneumatic, Standard Item
Rope Roller Fairlead	Optional Item
Oil	Industrial Gear Oil 220
Oil Capacity	0.4 Gallon [1.5 Liter]
Mounting Bolts	8×M27, Class 10.9
Mounting bolt pattern	24"×6.7/12.2" 8- Ø1.18 " 610mm×170/310mm 8- Ø30
Cable (Dia.× L)	Ø1.18 "×160 FT(Ø30mm×50m)
Drum size (Dia.× L)	Ø11.02 "×14.17 " (Ø280mm×360 mm)
Overall dimensions (L×W×H)	51.22"×30.31 "×21.46 " 1301mm×770mm×545mm
Gross Weight	1270 LBS [580 kg]

Line Pull And Line Speed In Layer

Layer	Rated Line Pull Per Layer	Maximum Line Speed Per Layer
1	55000 LBS (25000KG)	18 FPM [5.49 m/min]
2	47000 LBS [21300 KG]	21 FPM [6.40 m/min]
3	41000 LBS [18500 KG]	24 FPM [7.32 m/min]
4	36000 LBS [16300 KG]	27 FPM [8.23 m/min]
5	32000 LBS [14500 KG]	30 FPM [9.14 m/min]

WINCH ASSEMBLY DRAWING 25JP

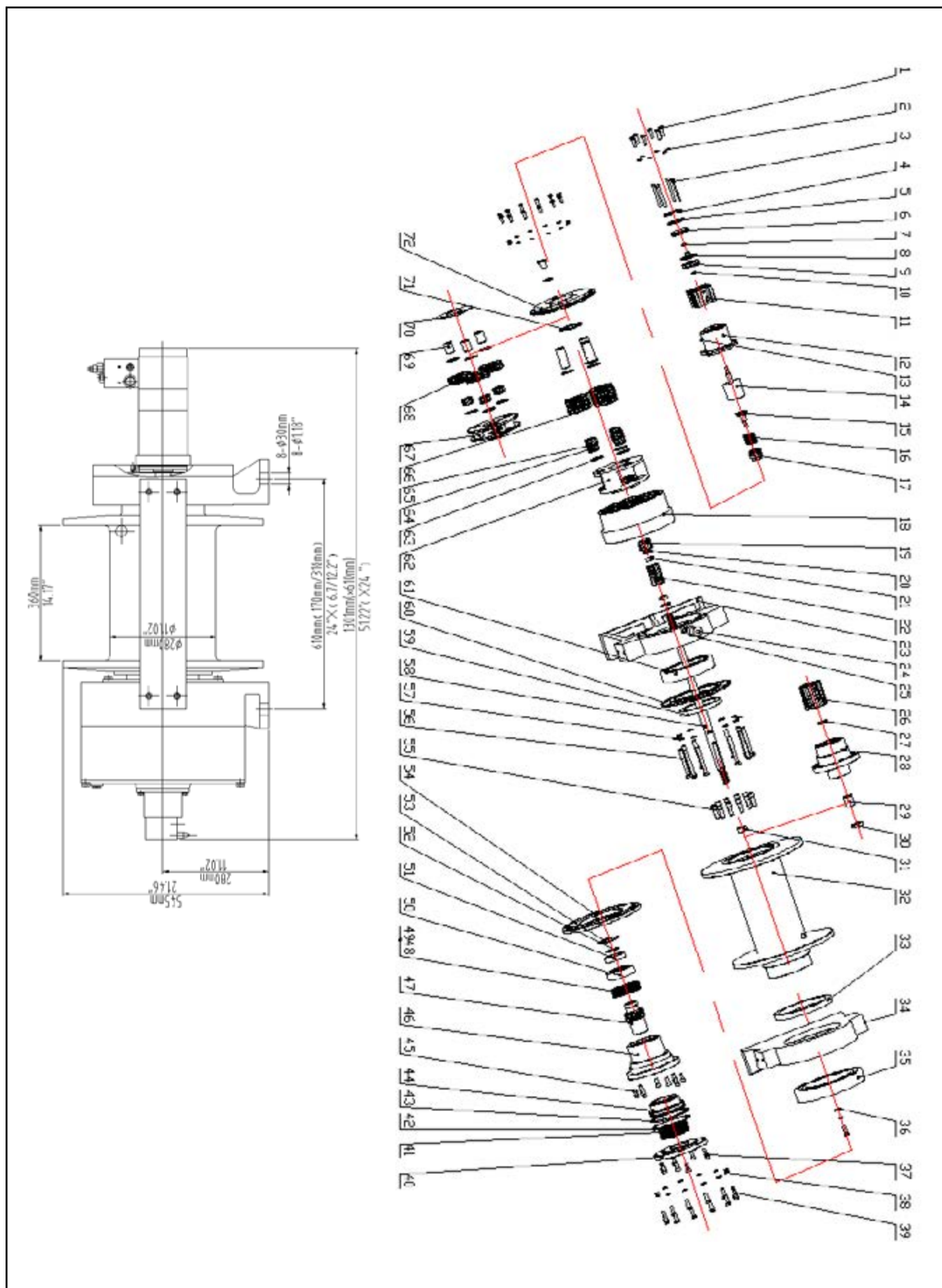

WINCH PARTS LIST (25JP)

#	Part Number	Description	Qty.
1	GB5783-86	Bolt M8*20	6
2	GB93-87	Gasket 8	6
3	GB70.1-2000	Screw M12*55	4
4	GB893.1-86	check ring 65	1
5	GB3452.1-2005	O-ring 58*2.65	2
6	IYJ100.1-1	Cylinder cover	1
7	GB/T6172.1-2000	Nut M10	2
8	GB3452.1-2005	O-ring 58*2.65	2
9	IYJ100.1-2	Bib	1
10	GB3452.1-2005	O-ring 58*2.65	1
11	IYJ100.1-9B	Cylinder liner	1
12	IYJ100.1-8	Air vat	1
13	IYJ150.4-2	Screw	1
14	IYJ150.4-1	Fork	1
15	IYJ100.1-5	Spring seat	1
16	IYJ100.1-4	Spring	1
17	IYJ250.4-3	linker	1
18	IYJ250-2	Gear ring	1
19	IYJ250-14	First stage sun gear	1
20	IYJ250-12	Cover	2
21	IYJ250.1-8	Cover	2
22	IYJ250.1-7	Second stage sun gear	1
23	IYJ250-10	The left bearing	1
24	JB1001-77	Ventilate plug screw	2
25	JB982-77	Gasket 20	2
26	IYJ250-11	Driver axle	1
27	IYJ150-12	Gasket	1
28	IYJ150-11	The middle axle	1
29	IYJ250-7	Gasket	1
30	GB3452.1-85	Oil seal 32x52x8	1
31	IYJ250-12	Gasket	1
32	IYJ250-4	Drum	1
33	GB9877.1-86	Oil seal 200*230*15	1
34	IYJ250-5	The right bearing	1
35	GB276-89	Bring 61938	1
36	IYJ150-7	Gasket	1
37	GB70-85	Screw M10*20	8

#	Part Number	Description	Qty.
38	GB93-87	Gasket 10	13
39	GB5783-86	Bolt M10*30	13
40	IYJ250.3-4	Motor seat	1
41	Z30A-16	Spring	16
42	GB3452.1-86	check ring A124*136*2	1
43	GB3452.1-86	O-ring 120*7	1
44	IHK3B21E.1-2	Bib	1
45	GB70-85	Screw M10*30	12
46	IYJ250.3-2	Brake cage	1
47	IYJ250.3-3	Splined hub	1
48	HS70K-11	Inner friction disc	6
49	HS70K-10A	outside friction disc	7
50	IYJ250.3-5	Bring seat	1
51	GB276-89	Bring 61916	1
52	GB893.1-86	check ring 75	1
53	JB/ZQ4341-1997	check ring 102*4	1
54	IYJ250.3-1	Cover	1
55	GB70-85	Screw M12*45	20
56	GB5782-86	Bolt M12*100	12
57	GB93-87	Gasket 12	12
58	IYJ250-6	Driver axle	1
59	GB9877.1-86	Oil seal 130*160*12	1
60	IYJ250-3	Driver axle	1
61	GB288-87	Bring 3053124	1
62	IYJ250.1-2	Second stage planet carrier	1
63	IYJ250.1-4	First stage planet gasket	12
64	GB309-84	Roller 5*21.8	252
65	IYJ250-9	Gasket	3
66	IYJ250.2-3	Second stage planet gear	3
67	IYJ250.1-6	First stage planet carrier	1
68	IYJ250.1-3	First stage planet gear	3
69	IYJ250.1-2	First stage planet axle	3
70	IYJ250.1-1	Gasket	1
71	IYJ250-13	Gasket	1
72	IYJ250-1	Cover	1

WINCH ASSEMBLY DRAWING 30JP

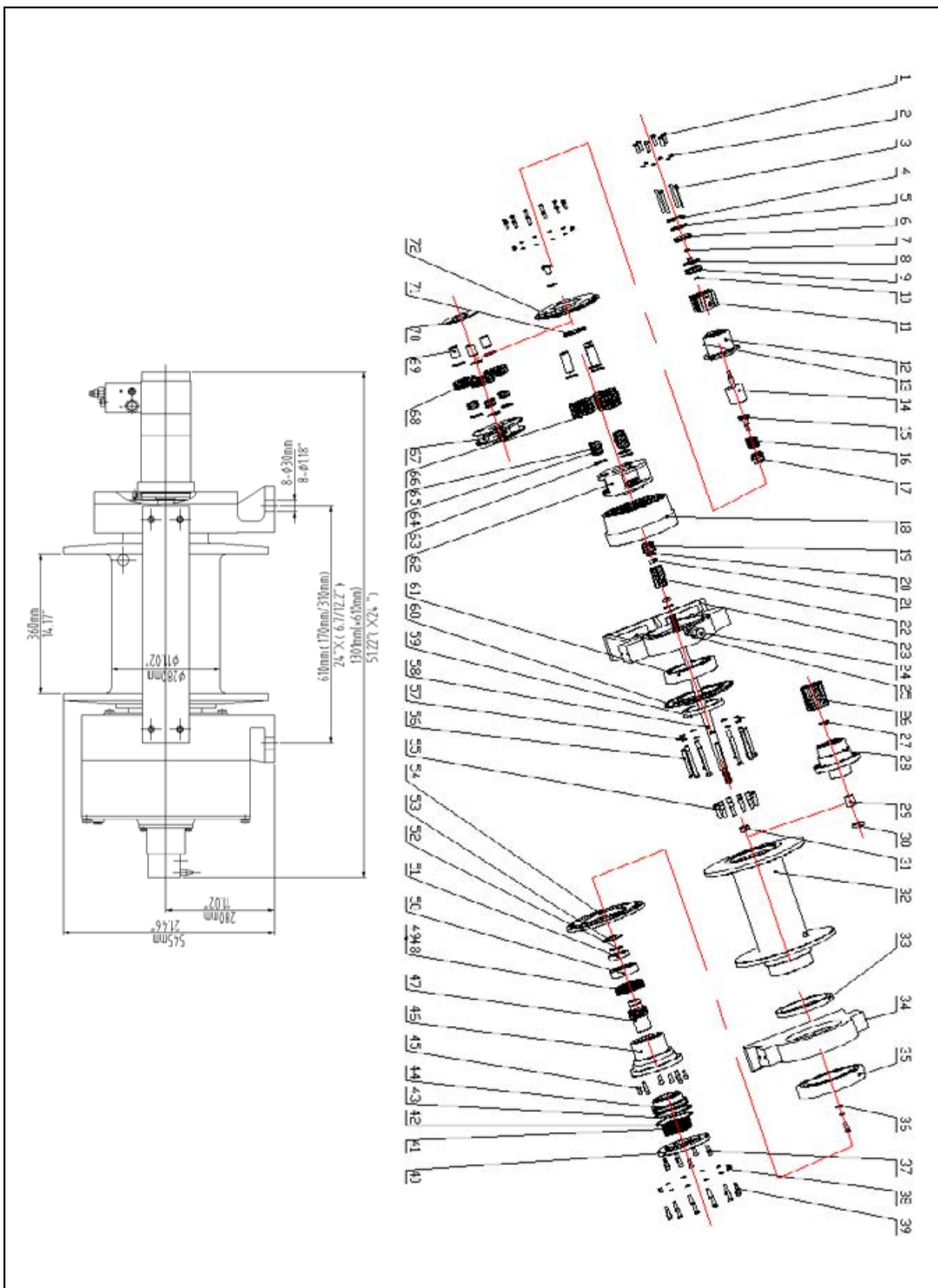

WINCH PARTS LIST (30JP)

#	Part Number	Description	Qty.
1	GB5783-86	Bolt M8*20	6
2	GB93-87	Gasket 8	6
3	GB70.1-2000	Screw M12*55	4
4	GB893.1-86	check ring 65	1
5	GB3452.1-2005	O-ring 58*2.65	2
6	IYJ100.1-1	Cylinder cover	1
7	GB/T6172.1-2000	Nut M10	2
8	GB3452.1-2005	O-ring 58*2.65	2
9	IYJ100.1-2	Bib	1
10	GB3452.1-2005	O-ring 58*2.65	1
11	IYJ100.1-9B	Cylinder liner	1
12	IYJ100.1-8	Air vat	1
13	IYJ150.4-2	Screw	1
14	IYJ150.4-1	Fork	1
15	IYJ100.1-5	Spring seat	1
16	IYJ100.1-4	Spring	1
17	IYJ250.4-3	linker	1
18	IYJ250-2	Gear ring	1
19	IYJ250-14	First stage sun gear	1
20	IYJ250-12	Cover	2
21	IYJ250.1-8	Cover	2
22	IYJ250.1-7	Second stage sun gear	1
23	IYJ250-10	The left bearing	1
24	JB1001-77	Ventilate plug screw	2
25	JB982-77	Gasket 20	2
26	IYJ250-11	Driver axle	1
27	IYJ150-12	Gasket	1
28	IYJ150-11	The middle axle	1
29	IYJ250-7	Gasket	1
30	GB3452.1-85	Oil seal 32x52x8	1
31	IYJ250-12	Gasket	1
32	IYJ250-4	Drum	1
33	GB9877.1-86	Oil seal 200*230*15	1
34	IYJ250-5	The right bearing	1
35	GB276-89	Bring 61938	1
36	IYJ150-7	Gasket	1
37	GB70-85	Screw M10*20	8

#	Part Number	Description	Qty.
38	GB93-87	Gasket 10	13
39	GB5783-86	Bolt M10*30	13
40	IYJ250.3-4	Motor seat	1
41	Z30A-16	Spring	16
42	GB3452.1-86	check ring A124*136*2	1
43	GB3452.1-86	O-ring 120*7	1
44	IHK3B21E.1-2	Bib	1
45	GB70-85	Screw M10*30	12
46	IYJ250.3-2	Brake cage	1
47	IYJ250.3-3	Splined hub	1
48	HS70K-11	Inner friction disc	6
49	HS70K-10A	outside friction disc	7
50	IYJ250.3-5	Bring seat	1
51	GB276-89	Bring 61916	1
52	GB893.1-86	check ring 75	1
53	JB/ZQ4341-1997	check ring 102*4	1
54	IYJ250.3-1	Cover	1
55	GB70-85	Screw M12*45	20
56	GB5782-86	Bolt M12*100	12
57	GB93-87	Gasket 12	12
58	IYJ250-6	Driver axle	1
59	GB9877.1-86	Oil seal 130*160*12	1
60	IYJ250-3	Driver axle	1
61	GB288-87	Bring 3053124	1
62	IYJ250.1-2	Second stage planet carrier	1
63	IYJ250.1-4	First stage planet gasket	12
64	GB309-84	Roller 5*21.8	252
65	IYJ250-9	Gasket	3
66	IYJ250.2-3	Second stage planet gear	3
67	IYJ250.1-6	First stage planet carrier	1
68	IYJ250.1-3	First stage planet gear	3
69	IYJ250.1-2	First stage planet axle	3
70	IYJ250.1-1	Gasket	1
71	IYJ250-13	Gasket	1
72	IYJ250-1	Cover	1

SPECIFICATIONS 30JP

Rated line pull Lbs (Kg)	66000 LBS (30000KG)
Rated Torque	33000 LBF-FT [41000 Nm]
Wire Rope Capacity	180 FT [55 m]
Wire Rope	Ø32 mm, Optional Item
Design Standard	ISO 4301 & SAE J706
Hydraulic Motor	Sauer Danfoss OMT 500
Hydraulic Operating Pressure	2465 PSI [17 MPa]
Free Spooling Clutch	Pneumatic
Pneumatic Clutch Pressure	0.4 - 0.8 MPa
Air Rope Tensioner	Standard Item
Rope Roller Fairlead	Optional Item
Oil	Industrial Gear Oil 220
Oil Capacity	0.4 Gallon [1.5 Liter]
Mounting Bolts	8×M27, Class 10.9
Mounting bolt pattern	24"×6.7/12.2" 8-Ø1.18 " 610mm×170/310mm 8-Ø30
Cable (Dia.× L)	Ø1.26 "×148 FT(Ø32mm×45m)
Drum size (Dia.× L)	Ø11.02 "×14.17 " (Ø280mm×360 mm)
Overall dimensions (L×W×H)	51.22"×30.31"×21.46 " 1301mm×770mm×545mm
Gross Weight	1433 LBS [650 kg]

Line Pull And Line Speed In Layer

Layer	Rated Line Pull Per Layer	Maximum Line Speed Per Layer
1	66000 LBS (30000KG)	13.3 FPM [4.07 m/min]
2	55500 LBS [25000 KG]	15.8 FPM [4.83 m/min]
3	48000 LBS [21000 KG]	18 FPM [5.59 m/min]
4	42000 LBS [19000 KG]	20.8 FPM [6.36 m/min]
5	37500 LBS [17000 KG]	23.3 FPM [7.12 m/min]

EC Declaration of Conformity

Zertifikatnr. / Certificat nr / Certificate No. MD-TCF220621-39334 -V10-BPE

Lieferant und Emittent / Fournisseur et émetteur / Supplier and Issuer:
BPE Solutions Deutschland GmbH, Altrottstrasse 31, 69190 Walldorf, Deutschland

Gerät(e) / Dispositif (s) / Equipment	Hydraulic Winch
Modell / Modèle / Model	10NHSY, 15NHSY, 80RVSHY, 80SDSDY, 10RVSHY, 10RVLDY, 15RVSHY, 18RVSHY, 2TRVSHY, 28RVLHY, 28RVLDY, 13HWTTSHY, 10JP01H, 10JP02H, 13JP01H, 15JP01H, 20JP01H, 25JP01H, 30JP01H
Seriennummer / numéro de série / Serial Number	

Gemäß den folgenden Richtlinien / Conformément aux directives suivantes
In accordance with the following directives :

Machinery Directive 2006/42/EC
Electromagnetic Compatibility Directive 2014/30/EU
RoHS Directive 2011/65/EU

Gemäß den folgenden Normen / Selon les normes suivantes /
In accordance with the following Standards:

BS EN 14492-1:2006+A1:2009	BS EN 60204-1:2018	BS EN IEC 61000-6-2:2019
BS EN IEC 61000-6-4:2019	BS EN ISO 12100:2010	BS EN ISO 3744:1995

Hiermit erkläre ich, dass das/die obengenannte(n) Gerät(e) gemäß den relevanten Abschnitten der obigen Anforderungen entworfen und hergestellt wurde(n). Die Produkte entsprechen den Grundanforderungen der relevanten Richtlinien und Normen. Dieses Zertifikat ist nur bei den obengenannten Produkten und Konfigurationen im Zusammenhang mit detaillierten Testdaten sowie mit allen zutreffenden rechtlichen Vorschriften des Produktes gültig.

Je déclare par la présente que le(s) dispositif(s) ci – dessus ont été conçus et fabriqués conformément aux sections pertinentes des exigences ci-dessus. Les produits satisfont aux exigences de base des directives et normes applicables. Ce certificat n'est valable que pour les produits et configurations ci-dessus en relation avec des données de test détaillées ainsi qu'avec toutes les réglementations légales applicables du produit.

I hereby declare that the equipment named above has been designed and manufactured to comply with relevant sections of the above referenced specifications. The products comply with the essential requirements of the relevant directives and standards. This certificate is only valid for the product(s) and configuration described in conjunction with details test data and with all applicable legal requirements of this product.

This declaration of conformity is issued under the exclusive responsibility of the manufacturer.

Datum / Date:	01.06.2022 09:52
Land / Pays / Issuing Country:	Deutschland

X *P. Binson*
Paul Binson
QA & Development Manager



Registered Technical File Holders Address
BPE Solutions Deutschland GmbH
Altrottstrasse 31
69190 Walldorf
Deutschland
DE 347460020

EC Declaration of Conformity

Certificate No. TEZJ22062139336-V10-BPE

Supplier and Issuer:

BPE Holdings Ltd, Unit 17/18A Bradley Hall Trad Est, Bradley Lane, Wigan, WN6 0XQ, UK

Equipment	Hydraulic Winch
Model	10NHSY, 15NHSY, 80RVSHY, 80SDSDY, 10RVSHY, 10RVLDY, 15RVSHY, 18RVSHY, 2TRVSHY, 28RVLHY, 28RVLDY, 13HWTTSHY, 10JP01H, 10JP02H, 13JP01H, 15JP01H, 20JP01H, 25JP01H, 30JP01H
Serial Number	

In accordance with the following directives :

Machinery Directive 2006/42/EC

In accordance with the following Standards:

BS EN 14492-1:2006+A1:2009	BS EN 60204-1:2018	BS EN ISO 12100:2010
BS EN IEC 61000-6-2:2019	BS EN IEC 61000-4-2:2019	

I hereby declare that the equipment named above has been designed and manufactured to comply with relevant sections of the above referenced specifications. The products comply with the essential requirements of the relevant directives and standards. This certificate is only valid for the product(s) and configuration described in conjunction with details test data and with all applicable legal requirements of this product.

This declaration of conformity is issued under the exclusive responsibility of the manufacturer.

Date:	28.06.2022 11:52
Issuing Country:	United Kingdom

X P Bimson

Paul Bimson
QA & Development Manager

**UK
CA**

Registered Technical File Holder
BPE Holdings Ltd
Unit 17/18A Bradley Hall Trad Est
Bradley Lane
Wigan
WN6 0XQ
UK

**For warranty and repair enquiries, please
contact the retailer where you purchased
your winch product.**

Service & Technical Contacts

United Kingdom:

BPE Holdings
Unit 17-18
Bradley Hall Trading Estate
Bradley Lane, Standish
Wigan, WN6 0XQ, UK
service@bpeholdings.co.uk

Germany:

BPE Solutions Deutschland GmbH
Altrottstraße 31
D-69190 Walldorf
Germany
support@bpeholdings.de

France:

BPE Solutions France SAS
3 Boulevard de Belfort
59000 Lille
France
sav@bpeholdings.fr