



OPERATING INSTRUCTIONS

Read and save these instructions.

TORQX 13

13500 LBS

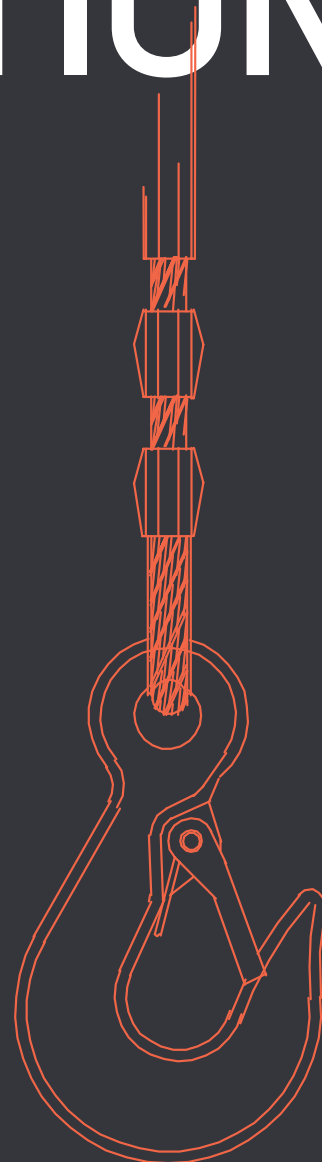

WARNING: Read carefully and understand all assembly and operation instructions before operating. Failure to follow the safety rules and other basic safety precautions may result in serious personal injury.

TABLE OF CONTENTS

PAGE REFERENCES

Technical Specifications	3
General Safety Information	4
Installation and Setup	5
Wiring Connections	7
Operating Instruction	8

**CHECK THE WINCH CAREFULLY
AND THOROUGHLY
BEFORE OPERATING!v**

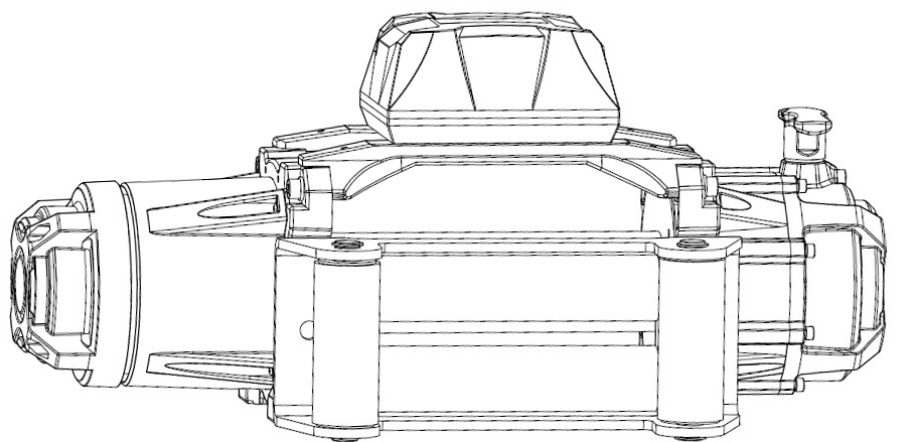

Property	Specification
Single line rated pull	13500 lbs (6136 kg)
Motor	12 V DC 6.8 hp, series wound
Gear train	3 stage planetary
Gear reduction ratio	216:1
Clutch (freespooling)	Sliding Ring Gear
Brake	Automatic In-The-Drum
Drum size	Ø 2.5" x length 9.0" (63.5 x 228 mm)
Cable	3/8" x 85' (9.5 mm x 26 m)
Fairlead	4-way Roller Fairlead
Recommended Battery	12 V DC Minimum 650 CCA
Battery leads	1.8 m long
Mounting bolt pattern	10" x 4.5" (254 x 114 mm)

Line pull (lbs / kg)	Line speed (fpm / mpm)	Motor Amps
0	24.27 (7.4)	76
3216 (1461)	9.06 (2.76)	163
6767 (3072)	7.74 (2.36)	272
10209 (4638)	5.58 (1.67)	297
13500 (6136)	4.27 (1.3)	395

GENERAL SAFETY PRECAUTIONS



PLEASE WORK SAFELY!













As you read these instructions, you will see **WARNINGS** and **CAUTIONS**. Each message has a specific purpose. **WARNINGS** and **CAUTIONS** identify the hazard, indicate how to avoid the hazard and advise of the probable consequence of not avoiding the hazard.

WARNINGS are safety messages that indicate a potentially hazardous situation, which if not avoided, can result in serious injury or death.







CAUTIONS are safety messages that indicate a potentially hazardous situation, which if not avoided, may result in minor or moderate injury. **A CAUTION** may also be used to alert against unsafe practice.

WARNING







To prevent serious injury and property damage:

-  ■ Do not operate or install winch without reading and understanding these instructions and the Basic Guide to Winching Techniques.
-  ■ Keep hands clear of rope, hook and fairlead opening during operation and when spooling.
-  ■ Use supplied hook strap for spooling rope.
-  ■ Stand clear of rope and load during operation.
-  ■ Keep others away.
-  ■ Inspect winch installation and rope condition before operating winch. Do not use as a hoist.
-  ■ Do not use to move persons.
-  ■ Do not exceed winch's rated capacity.
-  ■ Never touch rope or hook while in tension.
-  ■ Be certain the anchor you select will withstand load.
-  ■ Never wrap rope back onto itself. Use a choker chain, tree trunk protector or an anchor.
-  ■ Prior to initiating winching operation be sure any element which can interfere with safe winching is removed.
- ■ Do not disengage clutch if winch is under load or rope is under tension.

WARNING

-  ■ Take your time. Sloppy rigging causes accidents.
-  ■ The rope must always spool onto the drum as indicated by the drum rotation label on the winch.
-  ■ Batteries contain gases which are flammable.
-  ■ Wear eye protection. Remove all metal jewelry.
-  ■ Do not lean over battery while making connections.
-  ■ Failure to take proper precaution may result in fire or serious injury.

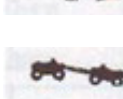
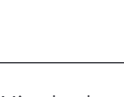
CAUTION

-  ■ Do not use winch to secure a load during transport.
-  ■ Do not submerge in water.
-  ■ Do not use to tow vehicles.
-  ■ Wear heavy leather gloves when handling the rope.
-  ■ Never winch with less than 5 wraps of rope around the drum.
-  ■ Caution should be used if the vehicle is tied down during a winching operation. This may lead to damage to the frame.
-  ■ Before winching, inspect remote control lead for damage.

UNPACKING

When unpacking, make sure that the item is intact and undamaged. If any parts are missing or broke, check the the table below.

Part Nr.	Part Description	Quantity
1	WINCH BODY	1
2	SQUARE-HEAD NUT	4
3	MOUNTING PLATE (OPTION)	1
4	NUT M12	2
5	WASHER M10	4
6	SPRING WASHER M10	4
7	HEX HEAD BOLT M10X25	4
8	CABLE	1
9	4-WAY ROLLER FAIRLEAD	1
10	WASHER M12	2
11	SPRING WASHER M12	2
12	HEX HEAD BOLT M12x25	2

MOUNTING THE WINCH

1. Select a mounting site on the vehicle bumper, truck bed, boat trailer or other suitable location, considering the routing needs as described in the „Wiring“ section of this manual.
2. Mount the Fairlead to the Mounting Frame using supplied bolts, nuts and washers.
3. Mount the Winch to the Mounting Frame using supplied Bolts and Lock Washers.
4. Place the Electric Winch and Frame at the location where it will be mounted. Use the Remaining holes in the Mounting Frame as a template to mark and drill holes for mounting.
5. Verify that the installation surface has no hidden components or structural pieces that will be damaged before drilling.

Figure A:
4-way roller fairlead and winch attachment
to frame (proportions and exact alignment
may vary).

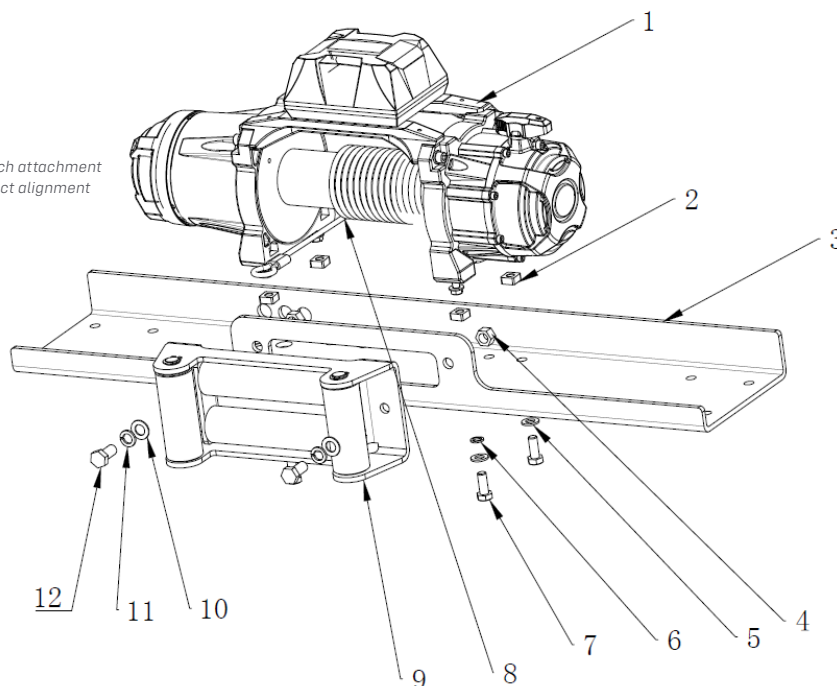

MOUNTING THE WINCH

USING A DIFFERENT PLATE

1. The plate must be rated to at least the winch's capacity.
2. Align the winch perpendicular to center line of the vehicle at the desired location, and mark the locations of the winch base holes. Compare the dimensions of the marked holes to Figure B.
3. Before drilling, verify that the installation surface has no hidden components or structural pieces that will be damaged.
4. Drill holes appropriate for the hardware at the marked locations.
5. Install the winch using the hardware specified on the specification chart.

Figure B - Winch Dimensions, measurement: mm

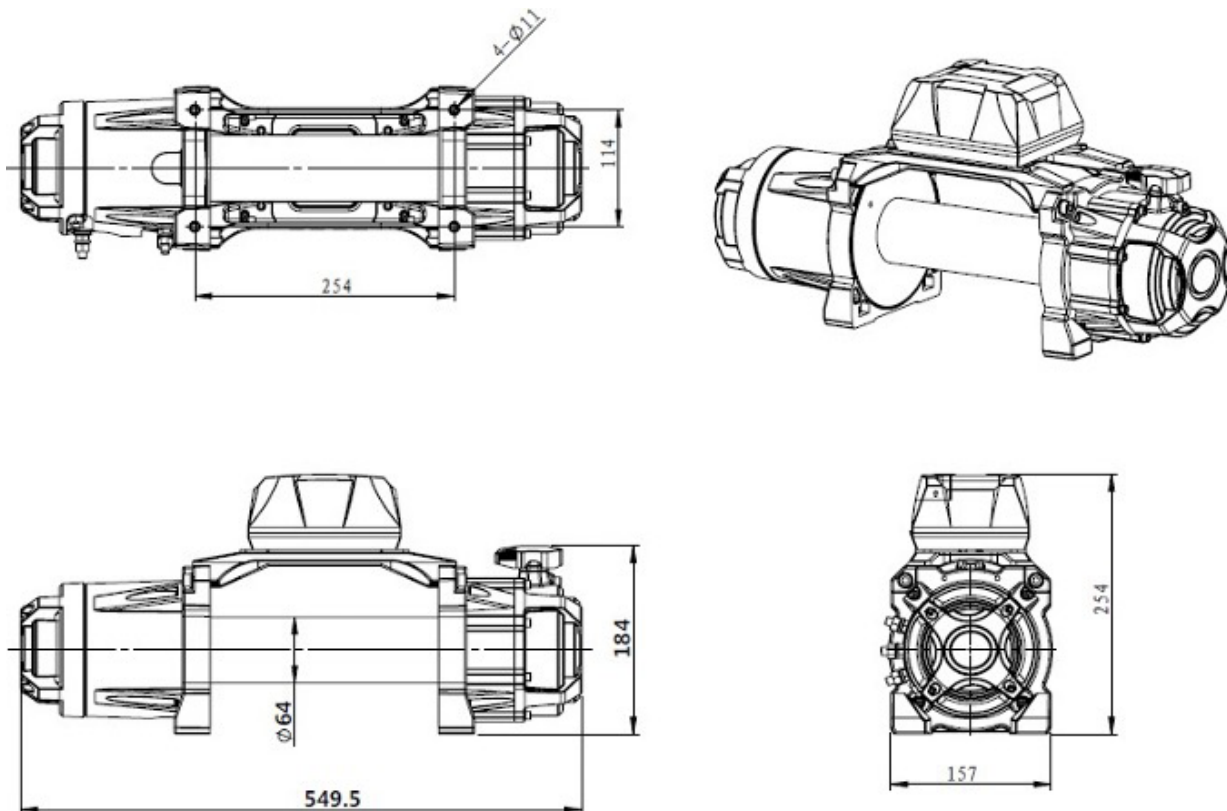



WARNING



BATTERY CONNECTION

Unplug the Connector and disconnect the Battery Cables before marking other wiring connections.



BATTERY ACID

To prevent serious injury from leaking battery acid, please note the following information. Do not use a dirty, corroded or leaking battery. Only use a 12V automotive (or equivalent) battery, in good condition.

WIRING

1. Plan a route for the wiring from the point of the vehicle where the winch will be mounted, or used to the battery. This route must be secure, out of the way of moving parts, road debris, or any possibility of being damaged by operation or maintenance of the vehicle. For example, you may wish to route the wires under the vehicle, attaching it to the frame using suitable fasteners. Do not attach the wires to the exhaust system, drive shaft, emergency brake cable, fuel line, or any other components which may damage the wiring through heat or motion, or create a fire hazard.

2. If you drill through the bumper or any part of the body to route the wires, be sure to install a rubber grommet in the hole to prevent fraying of the wires at that point.

3. Route the Cables from the Solenoid to the battery and from the Solenoid to the Winch, following the precautions discussed above. See Figure C.

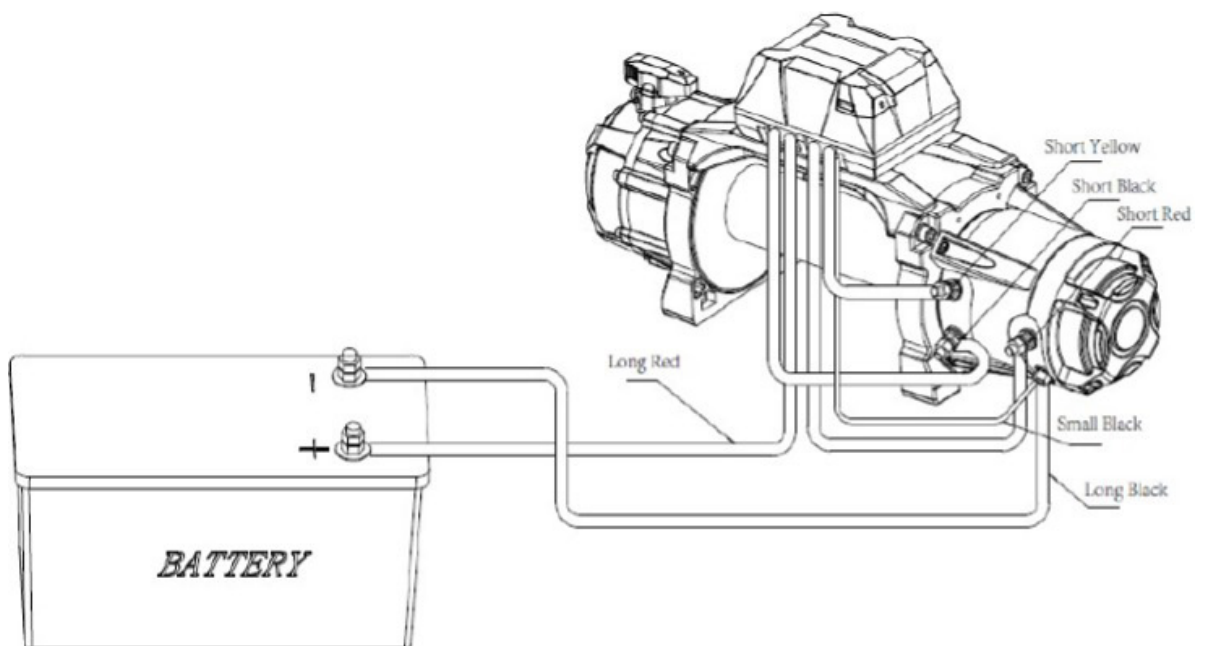

Figure C - Wiring Connections

WINCH OPERATION



PREPARING THE ROPE

1. The rope must be properly coiled under tension to be able to support a load without damage.
2. Uncoil the wire rope, except for 8 full wraps.
3. Recoil the wire rope back into the winch under at least 500 lb (230 kg) of load.

OPERATION

1. Examine the rope. Do not use the winch if the rope is frayed, kinked or damaged.
2. Fully charge the vehicle's battery.
3. Check the Winch's electrical connections. All connections must be tight and clean.
4. Put the vehicle's transmission in Neutral.
5. If the vehicle where the winch is mounted is not supposed to be moved, engage the emergency brake and block the wheels using wheel chocks (sold separately).
6. To pull out the rope, move the Clutch Handle to the Release position, shown in Figure D, slide the loop of the Hook Strap over the hook, then pull on the Hook Strap to pull out the rope. **WARNING! LEAVE AT LEAST 8 FULL TURNS OF ROPE ON THE DRUM.**

7. Hook onto the object using a pulling point, tow strap, tree strap, or chain. See Figure E.



Figure E - Using a strap anchor point

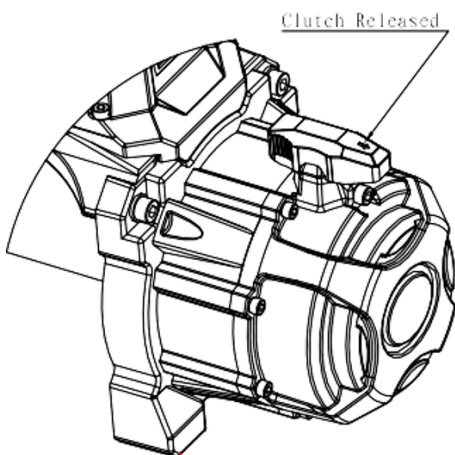

Figure D - Clutch Released

8. **DO NOT WRAP THE ROPE AROUND THE OBJECT AND HOOK ONTO THE ROPE BACK ONTO ITSELF.** This can damage the object being pulled, and kink or fray the rope.

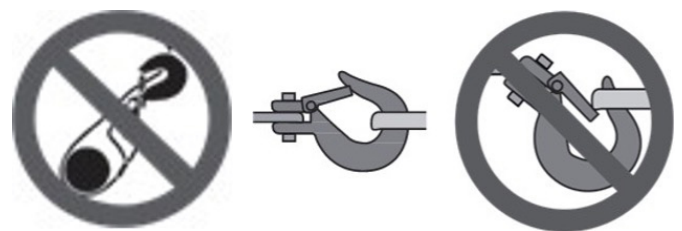

Figure F - Correct and incorrect hook attachment

9. **DO NOT USE A RECOVERY STRAP WHILE WINCHING.** They are designed to stretch and can suddenly whip back towards the operator during a winching operation.



10. Place a winch damper over the rope span, 6 feet from the hook to help absorb the force released if the rope breaks. See Figure G.

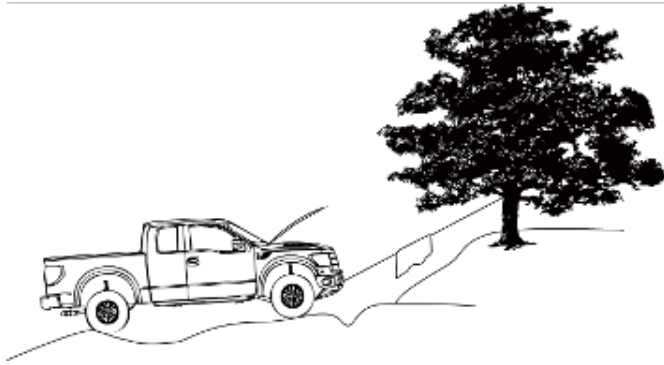

Figure G - Winch damper

WARNING! Do not allow anyone to stand near the rope, or in line with the rope behind the winch while it is under power. If the rope should slip or break, it can suddenly whip back towards the winch, causing a hazard for anyone in the area. Stand well to the side while winching.

11. When it is safe to do so, use the power switch on the Controller to retract the rope, and winch the item as desired. Do not power the hook all the way into the fairlead to prevent damage.

12. Do not operate the winch at extreme angles. Do not exceed the angles shown in Figure H for a roller fairlead. For a hawse fairlead, the angle should be as close to straight as possible.

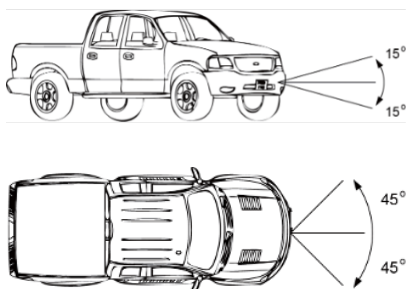

Figure H- Roller Fairlead maximum winching angles

13. If the object to be pulled must be pulled at an angle in relation to the winch, use a pulley (sold separately) and an anchor point directly in front of the winch, as shown in Figure I, to keep the Rope pull straight.

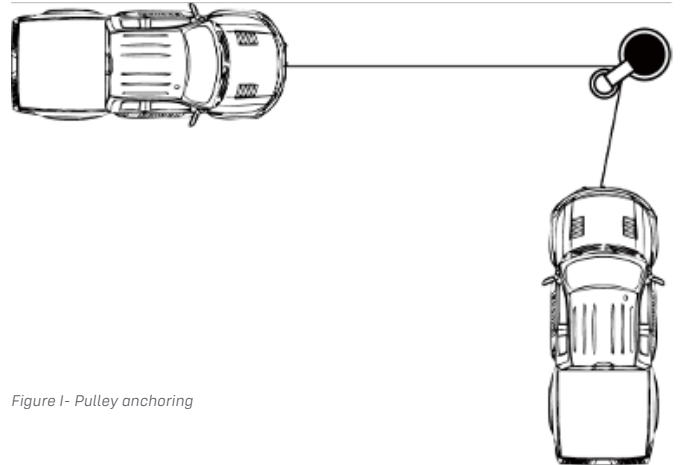

Figure I- Pulley anchoring

14. WARNING! Stop the winch and release tension on the rope before moving the winch damper on it.

15. Do not continue use of the winch until the battery is completely run down.

16. You may wish to keep the engine running while using this winch, to continually recharge the battery. However, exercise extreme caution when working around a running vehicle and **ONLY** operate a vehicle in an outdoor area.

CAUTION: Do not use the winch in a constant duty application, it is designed for **INTERMITTENT USE ONLY**. Keep the duration of the pulling job as short as possible. If the motor becomes very hot to the touch, stop and let it cool down for several minutes. Do not pull for more than 50 seconds at or near the rated load. Do not maintain power to the Winch if the motor stalls. Double Line Rigging will help prevent overloading and should be used whenever practical.

17. When finished pulling the load, reverse the direction of the winch just enough to release tension on the Rope so that you can unfasten the Hook from the load and reel in the Rope.

