

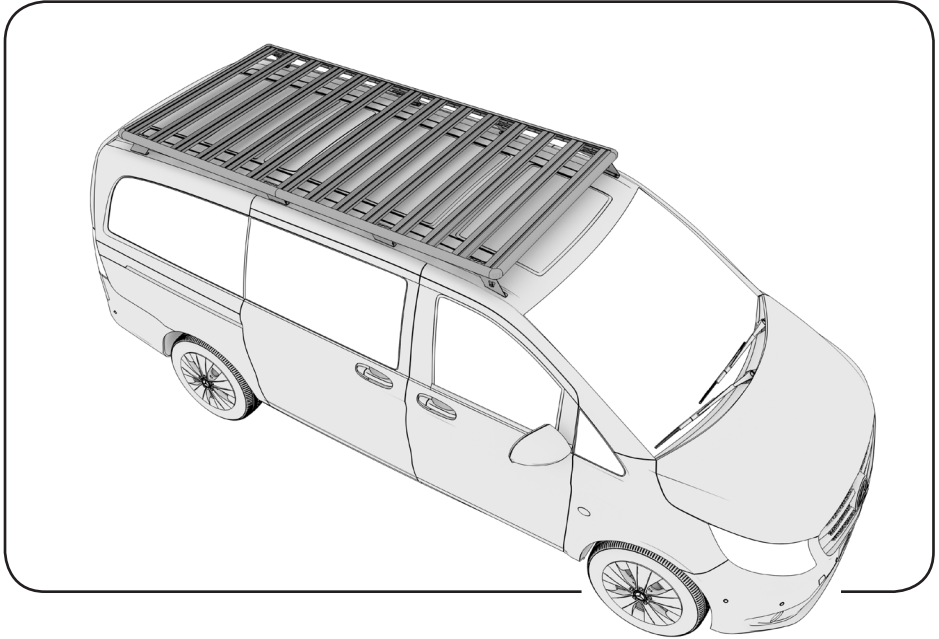

INSTRUCTIONS

ASSEMBLY INSTRUCTIONS MB VITO TOURER / V-KLASSE / V-KLASSE



VICKYWOOD

READ ME! ⚠

THANK YOU FOR CHOOSING VICKYWOOD. BEFORE YOU START ASSEMBLING YOUR ROOFRACK, TAKE A MOMENT TO CHECK OUT THE COMPONENTS AND LOOK THROUGH THE INSTRUCTIONS. ON THE NEXT PAGE YOU'LL FIND A LIST OF ALL COMPONENTS AND TOOLS REQUIRED.

IMPORTANT IN WARNING ⚠

ENSURING THE PROPER ASSEMBLY AND SECURE ATTACHMENT OF ALL VICKYWOOD PRODUCTS TO YOUR VEHICLE IS OF PARAMOUNT IMPORTANCE. IMPROPER INSTALLATION MAY RESULT IN ACCIDENTS, POSE DANGEROUS RISKS OF INJURY, OR EVEN FATALITIES. THUS, IT IS CRUCIAL TO VERIFY THAT EVERY COMPONENT IS ASSEMBLED ACCURATELY AND FIRMLY ATTACHED TO YOUR VEHICLE. YOU ARE RESPONSIBLE FOR THOROUGHLY INSPECTING ALL ATTACHMENTS BEFORE USAGE AND CHECKING THE PRODUCTS FOR ADJUSTMENTS, WEAR AND DAMAGE ON A REGULAR BASIS. CONSEQUENTLY, IT IS MANDATORY TO READ AND COMPREHEND ALL THE PROVIDED INSTRUCTIONS AND SAFETY PRECAUTIONS ACCOMPANYING YOUR VICKYWOOD PRODUCT BEFORE INSTALLATION OR USE. IF YOU ENCOUNTER DIFFICULTIES IN UNDERSTANDING THE PROCEDURES OR LACK MECHANICAL EXPERTISE, IT IS HIGHLY RECOMMENDED TO ENLIST THE SERVICES OF A PROFESSIONAL INSTALLER OR OTHER QUALIFIED INDIVIDUALS.

IMPORTANT NOTE: VICKYWOOD WILL NOT ASSUME RESPONSIBILITY FOR ANY DAMAGES RESULTING FROM FAILURE TO ADHERE TO THESE INSTALLATION INSTRUCTIONS. FEEL FREE TO CONTACT US SHOULD YOU HAVE ANY QUERIES REGARDING THE INSTALLATION OF THIS PRODUCT.

GENERAL OVERVIEW

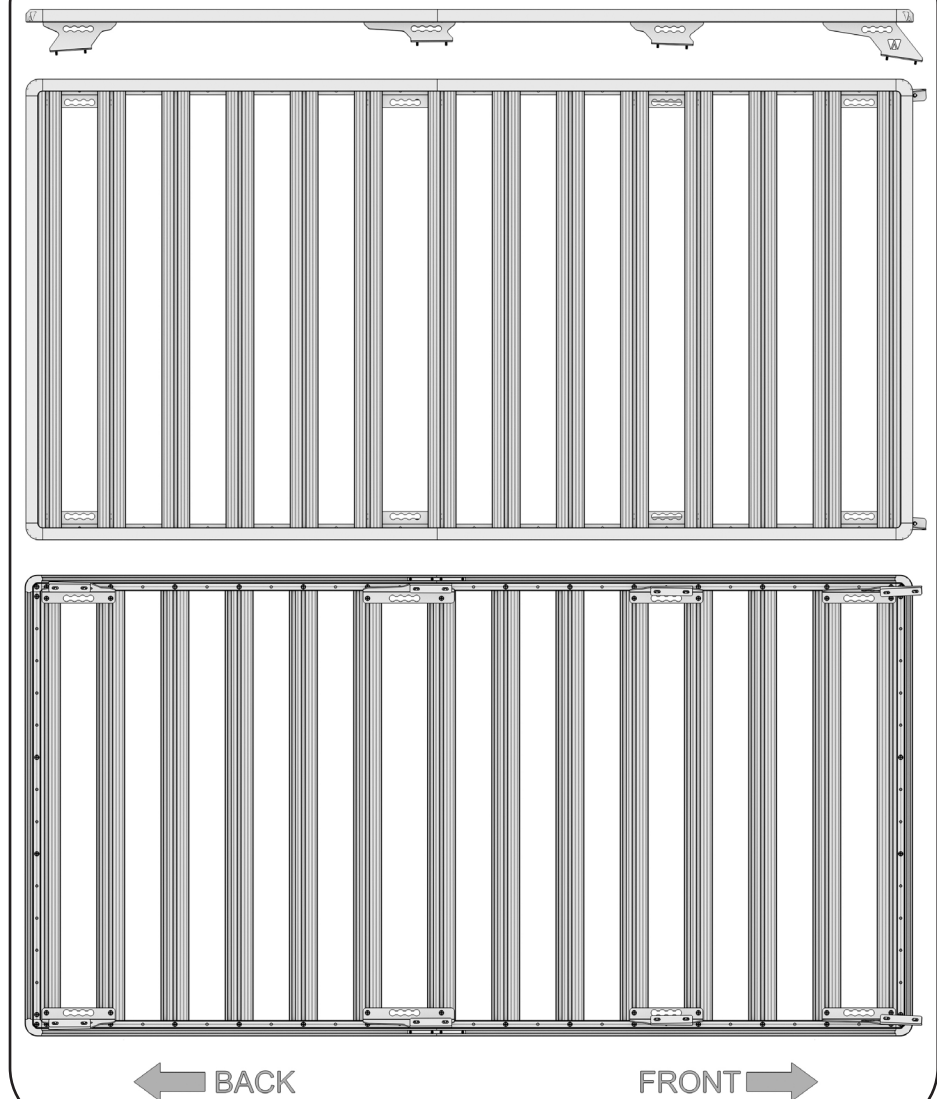

PARTS LIST

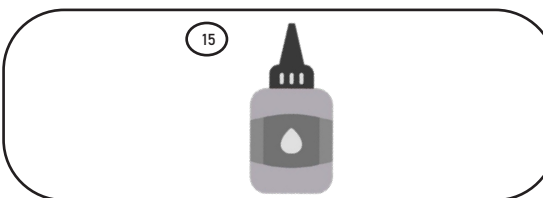
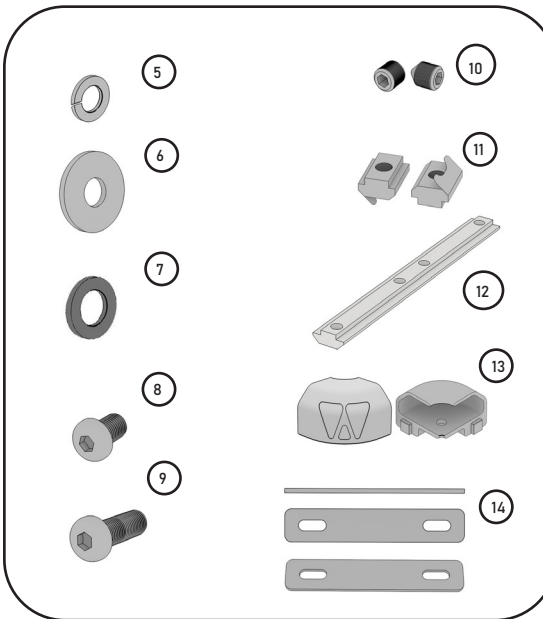
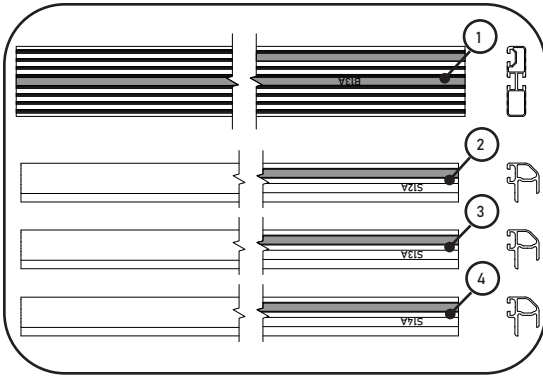

PARTS:

1. BOTTOM PROFILE B13A - 4 PCS
2. SIDE PROFILE S12A - 2 PCS.
3. SIDE PROFILE S13A - 2 PCS.
4. SIDE PROFILE S14A - 2 PCS.
5. SPRING RING - DIN 127 - B - 58 PCS.
6. WASHER - DIN 9021 - A2- 16 PCS.
7. WASHER - A8,4 - TYPE A - 56 PCS.
8. BOLT- ISO 7380-1 - M8 X 16 - 56 PCS.
9. BOLT - ISO 7380-1 - A2 M6X20 - 16 PCS.
10. SCREW- ISO 4027 - M8 X 10(1) - 8 PCS.
11. T NUT WITH SPRING LEAF - 58 PCS.
12. LONG SIDE T NUT - 2 PCS.
13. CORNER - 4 PCS.
14. RUBBER PAD - 8 PCS.
15. SCREW LOCK - 11 PC.
16. BRACKET FIRST PAIR - 2 PCS.
17. BRACKET SECOND PAIR - 2 PCS.
18. BRACKET THIRD PAIR - 2 PCS.
19. BRACKET FOURTH PAIR - 2 PCS.

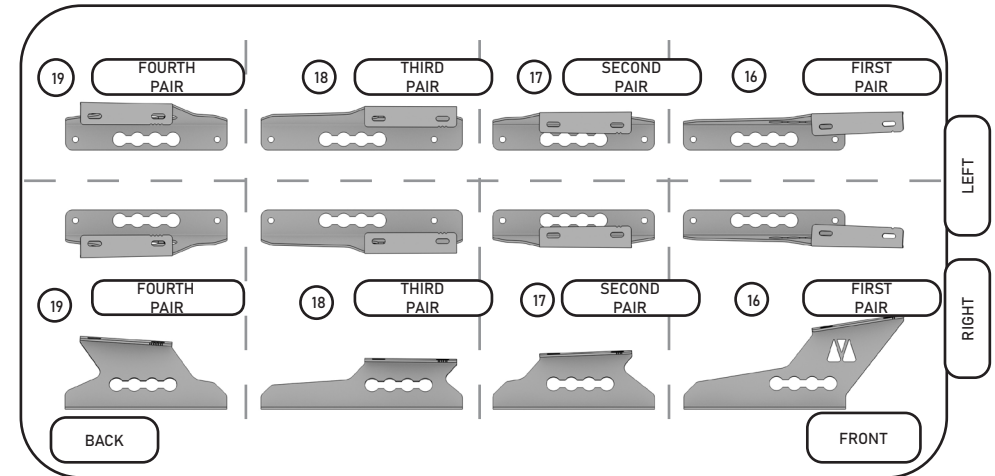

REQUIRED TOOLS

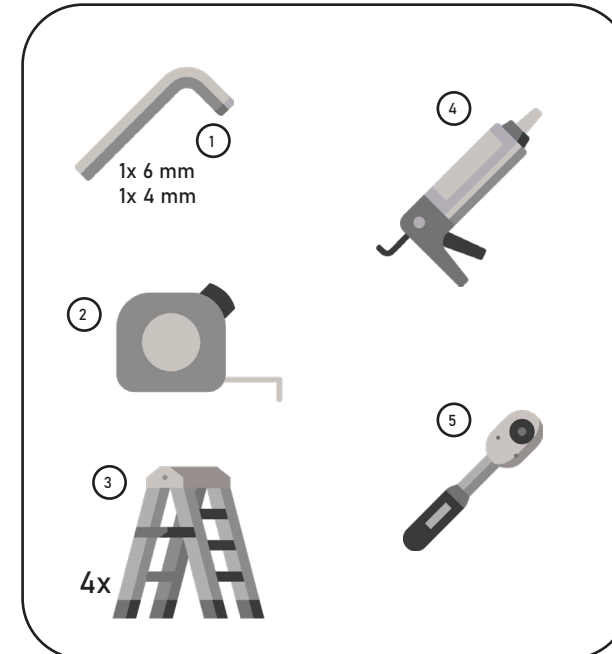

PREQUIRED TOOLS:

1. ALLEN KEY 4 MM + 6 MM
2. TAPE MEASURE
3. 4X STEP LADDER (TO LIFT THE RACK ONTO THE VEHICLE)
4. AUTOMOTIVE SEALANT
5. TORQUE WRENCH

HELPING HANDS FOR LIFTING THE RACK ONTO THE VEHICLE:

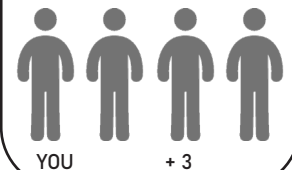



TOOLS NEEDED: 1. MEASURING TAPE, 2. HEX KEY 4 MM, 3. HEX KEY 6 MM

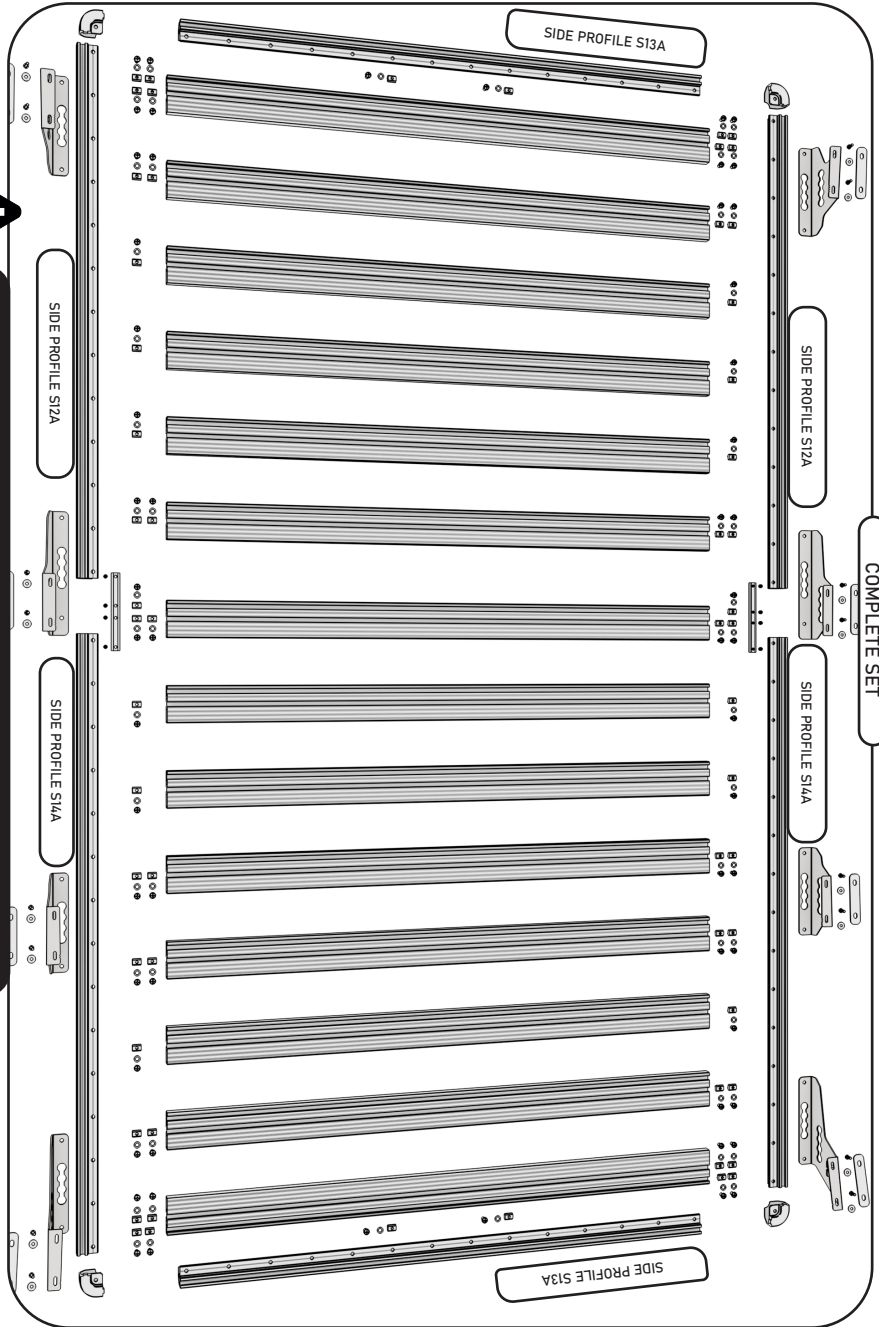

ASSEMBLE ON A FLAT HORIZONTAL SURFACE TO AVOID WARPING AND BACKLASH, UPSIDE DOWN.

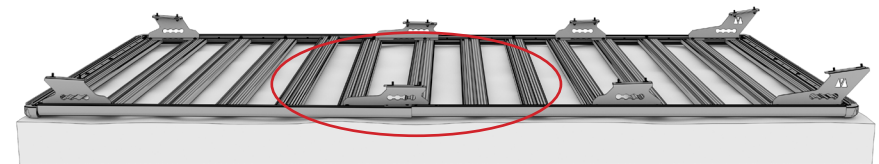
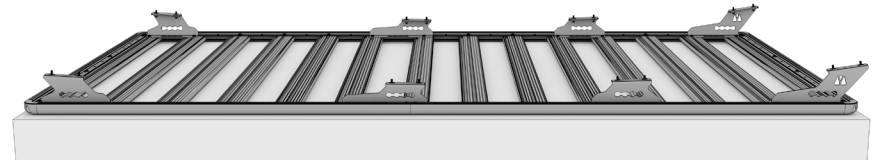
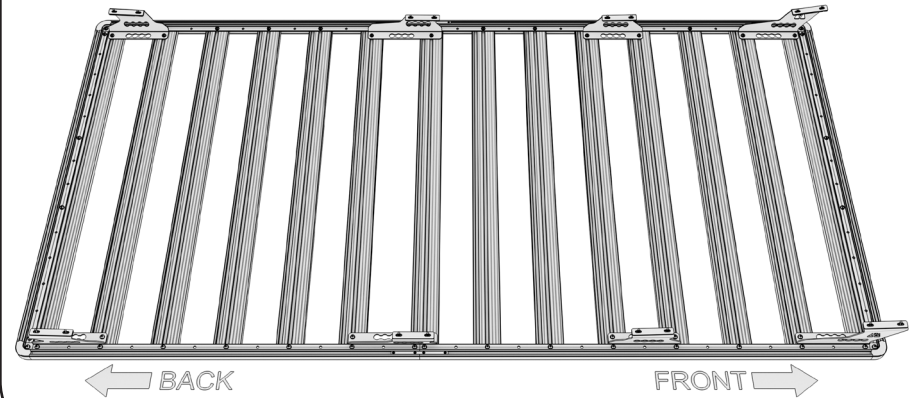

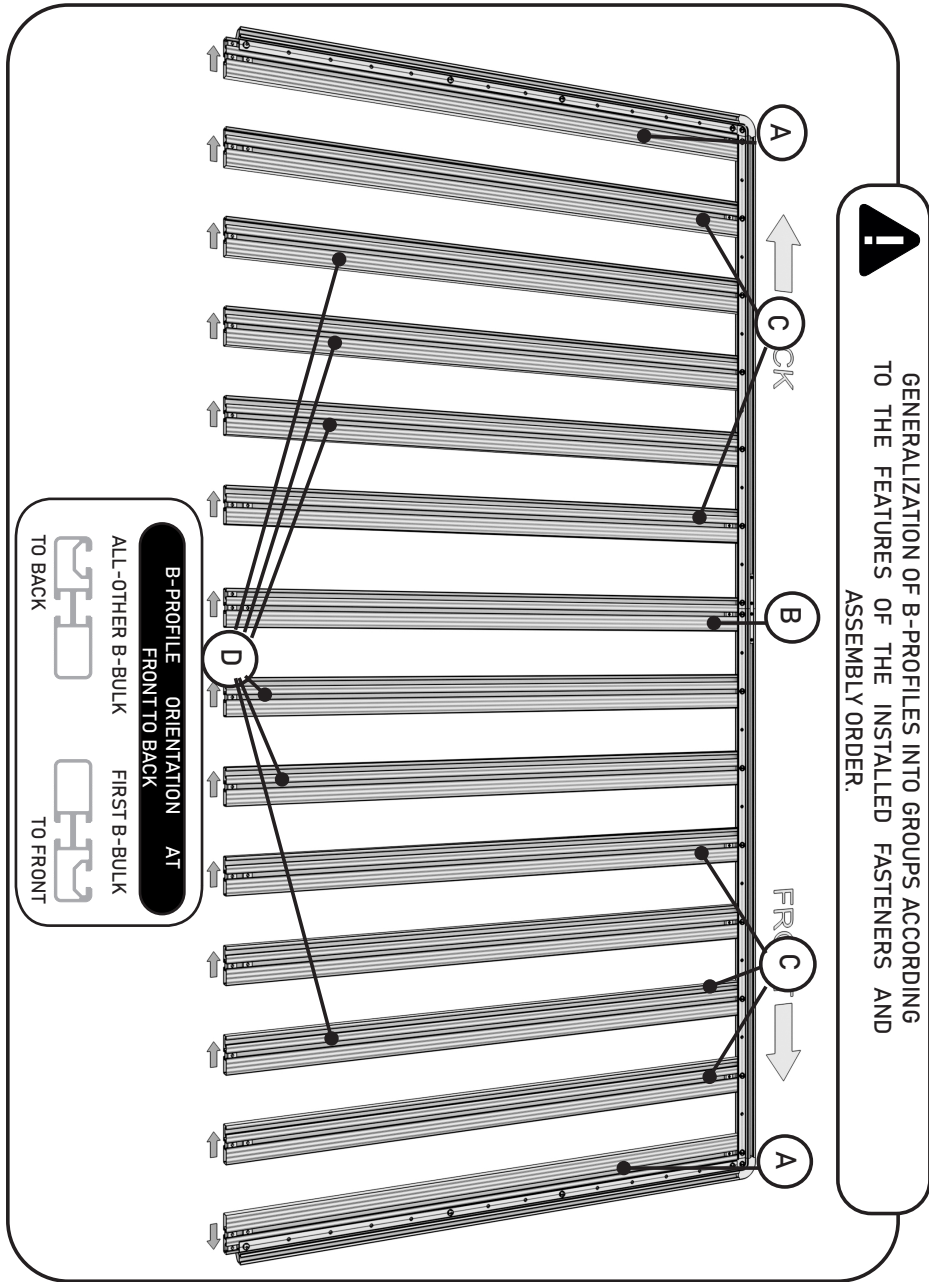

HOW TO ADD T NUTS TO YOUR PROFILES

WAY 1

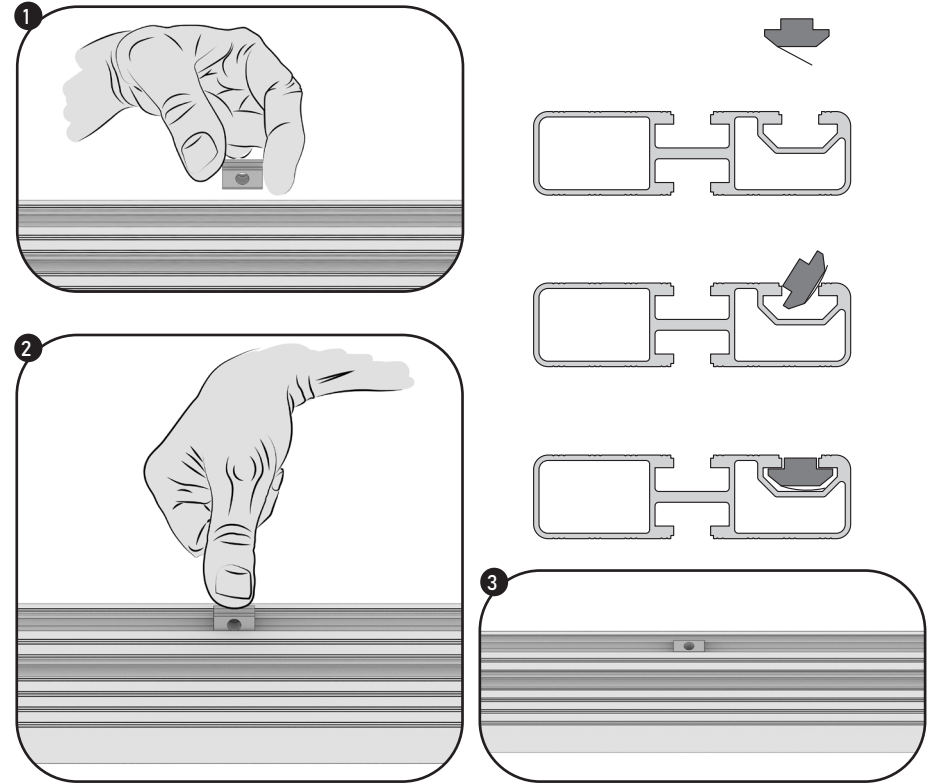

WAY 2

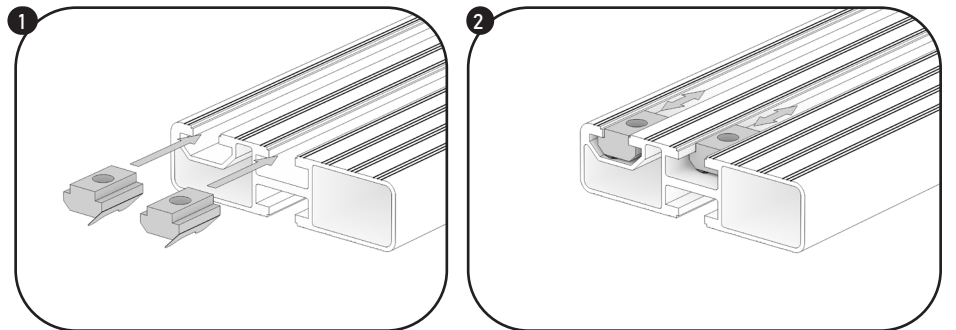



INSTALLATION T NUT TO THE PROFILES GROUP A

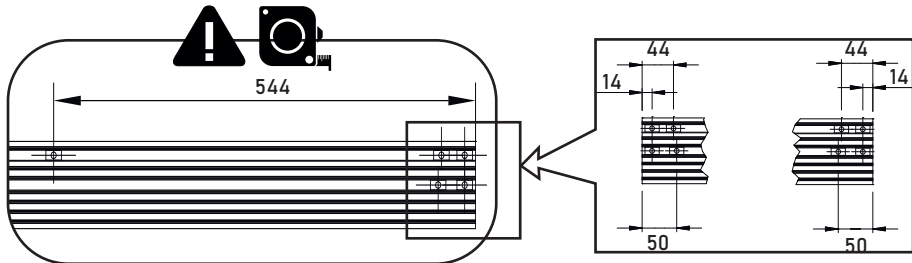
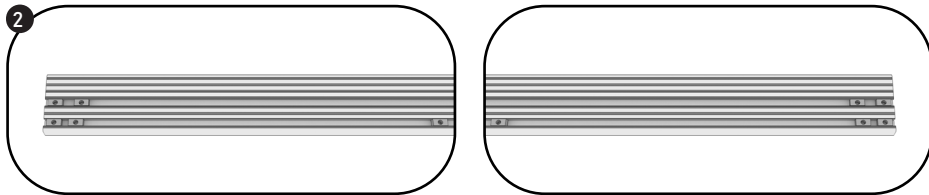
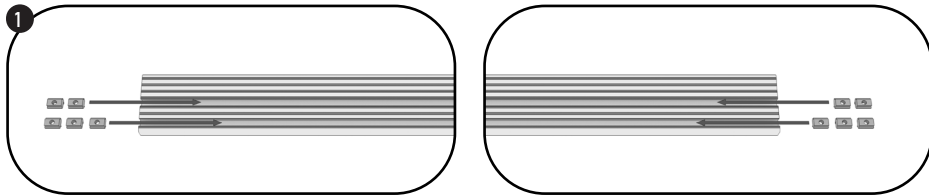
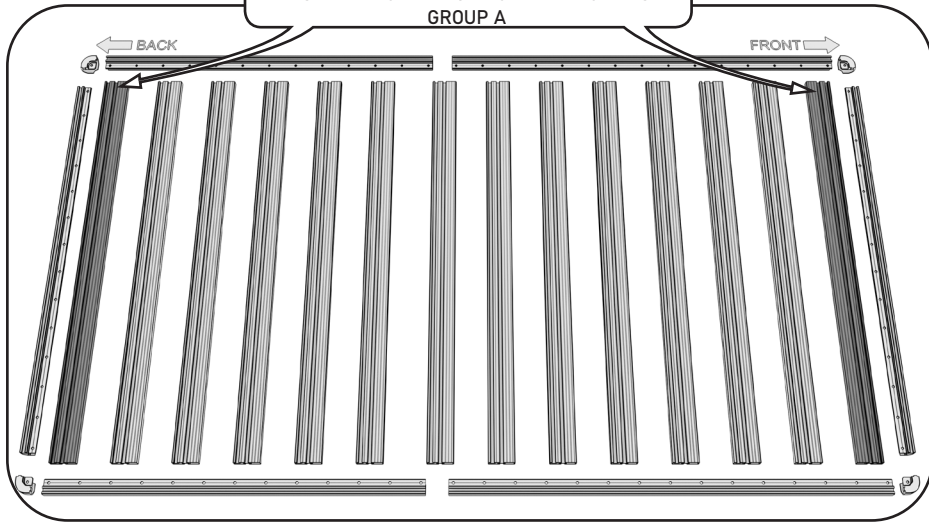

INSTALLATION T NUT TO THE PROFILES GROUP B

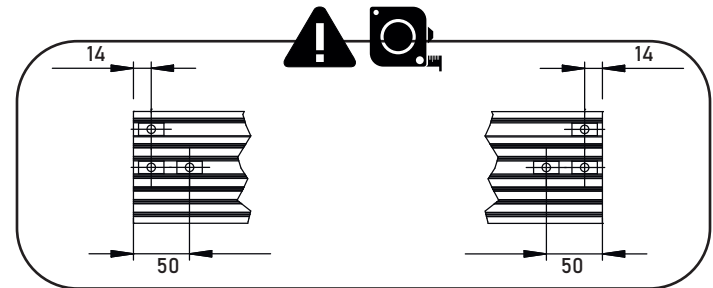
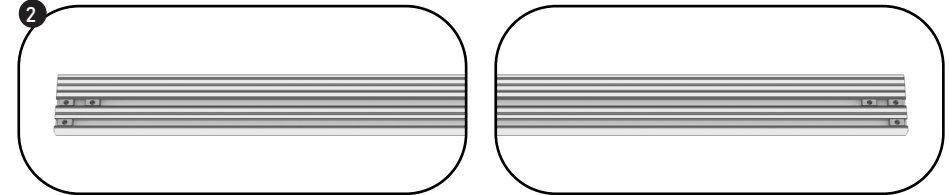
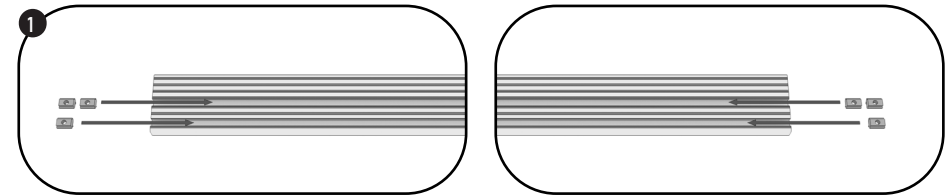
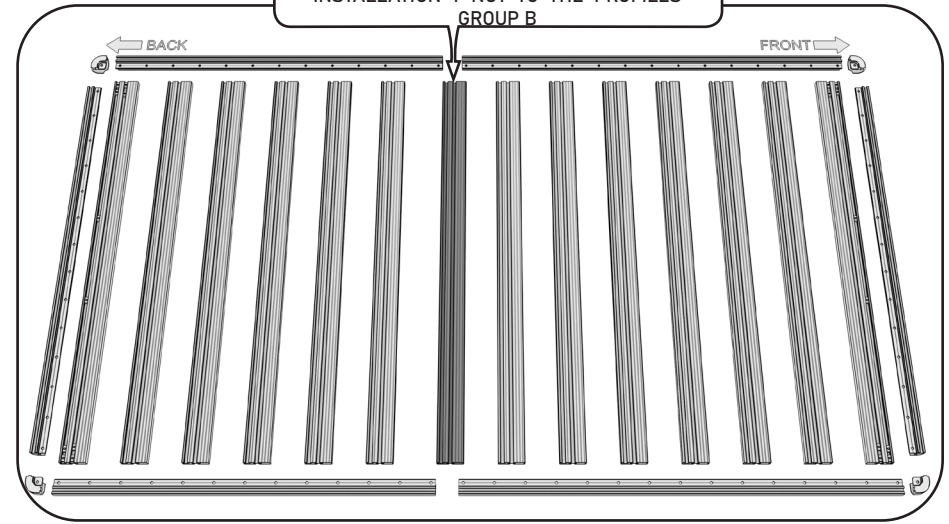



INSTALLATION T NUT TO THE PROFILES GROUP C

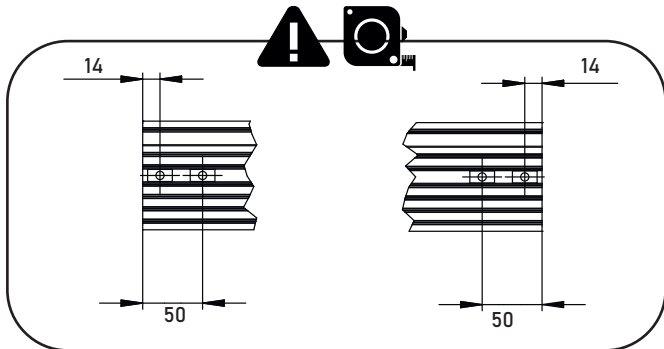
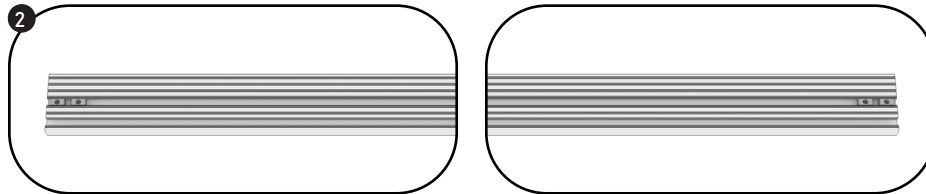
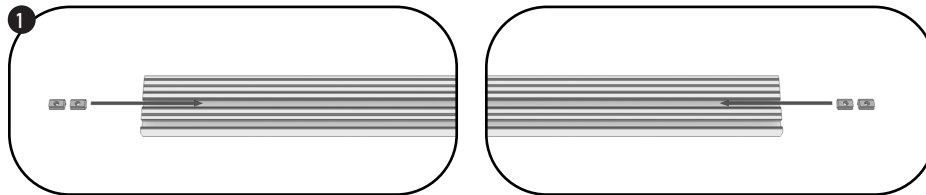
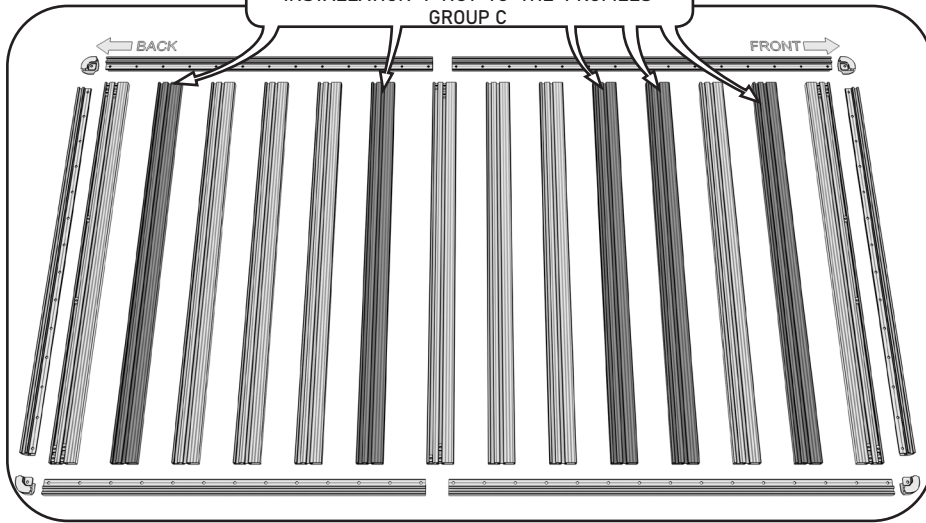

INSTALLATION T NUT TO THE PROFILES GROUP D

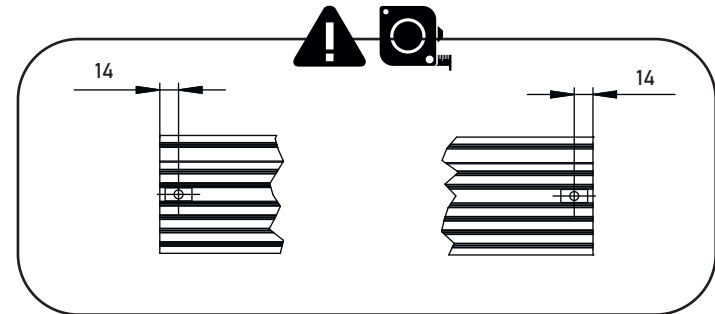
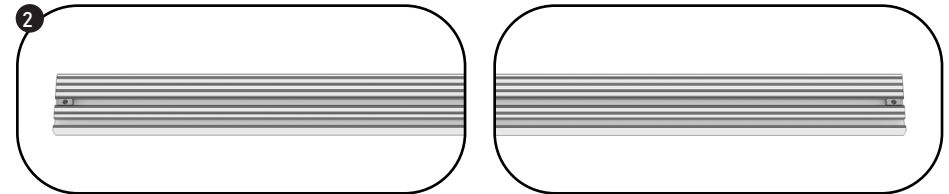
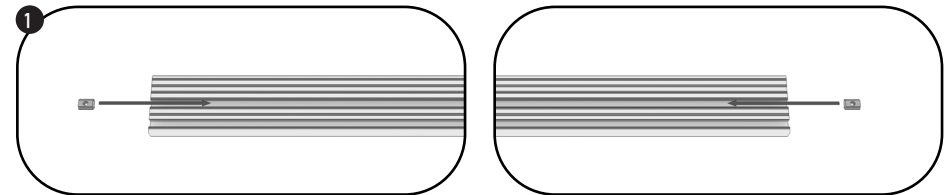
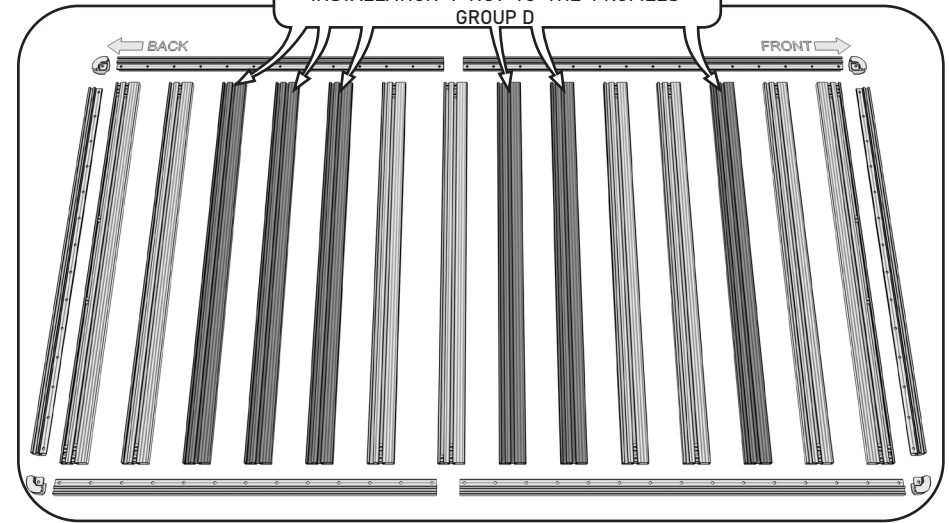

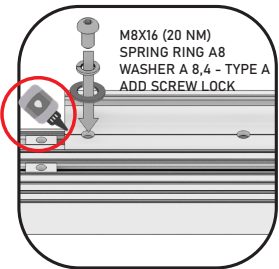
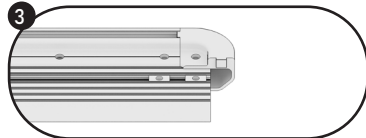
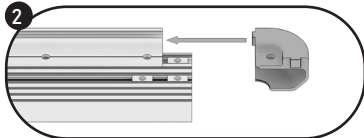
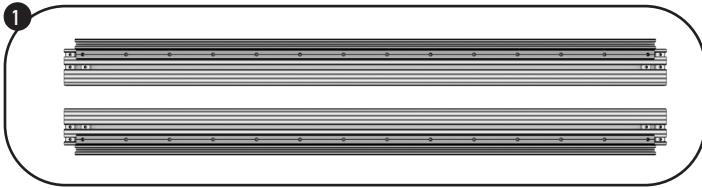
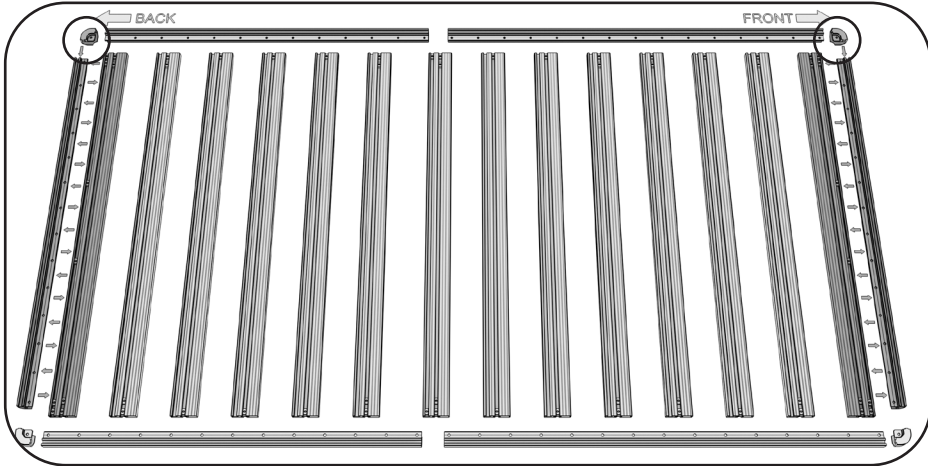

M8X16 (20 NM)
SPRING RING A8
WASHER A 8,4 - TYPE A
ADD SCREW LOCK

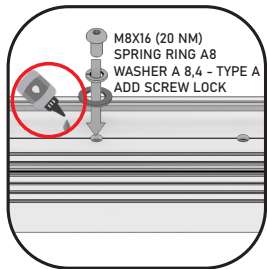

M8X16 (20 NM)
SPRING RING A8
WASHER A 8,4 - TYPE A
ADD SCREW LOCK

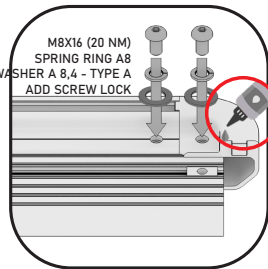

M8X16 (20 NM)
SPRING RING A8
WASHER A 8,4 - TYPE A
ADD SCREW LOCK

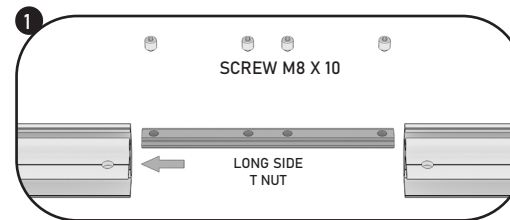
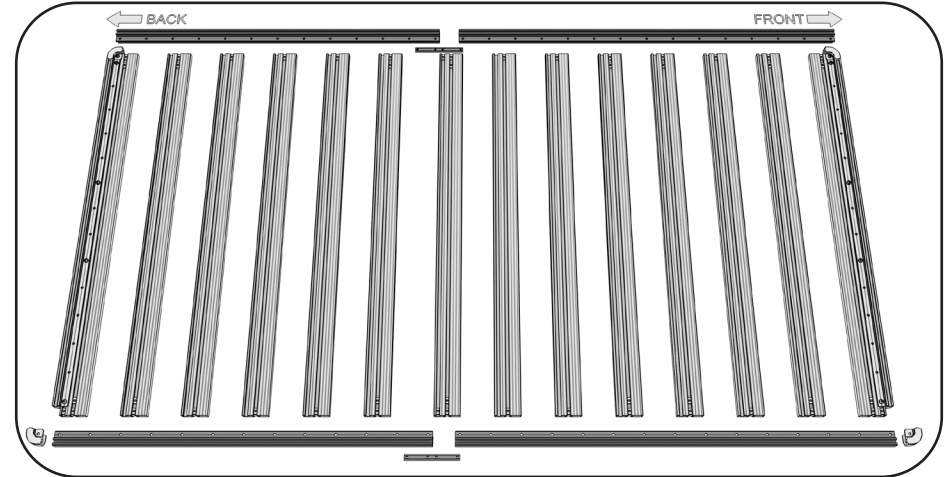
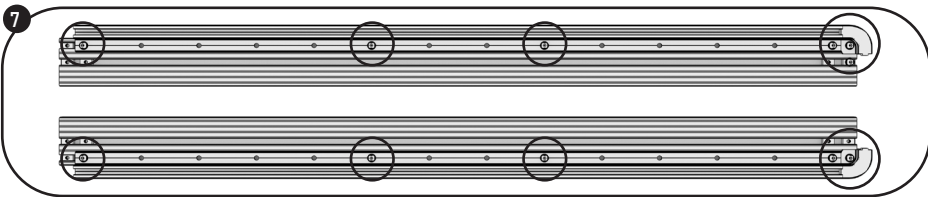

SCREW M8 X 10

LONG SIDE
T NUT

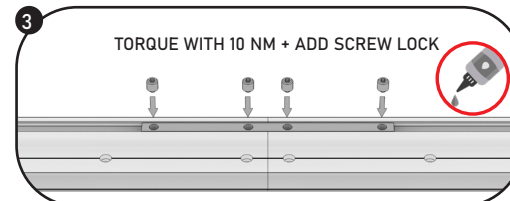
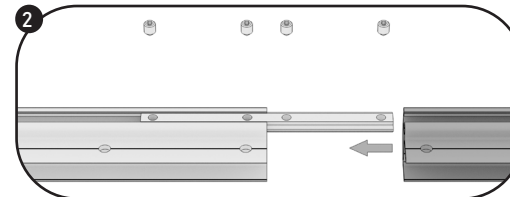

TORQUE WITH 10 NM + ADD SCREW LOCK

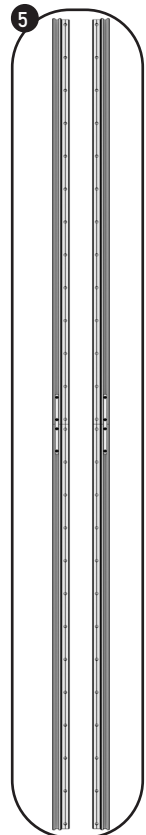
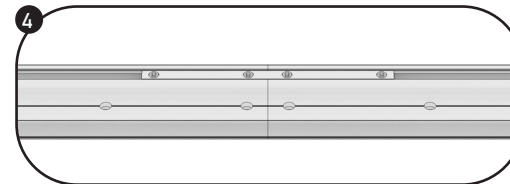

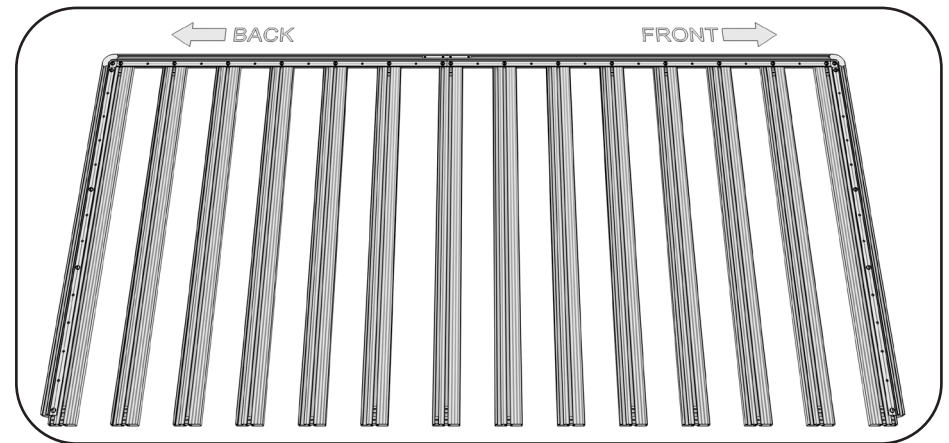
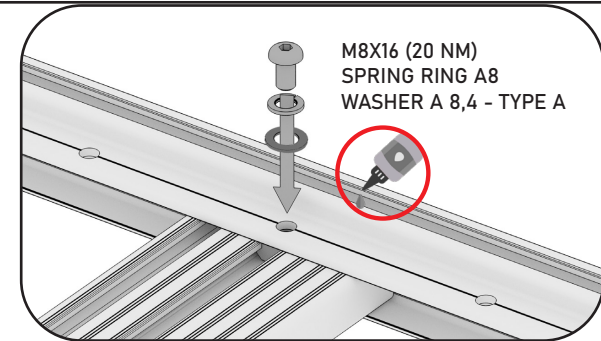
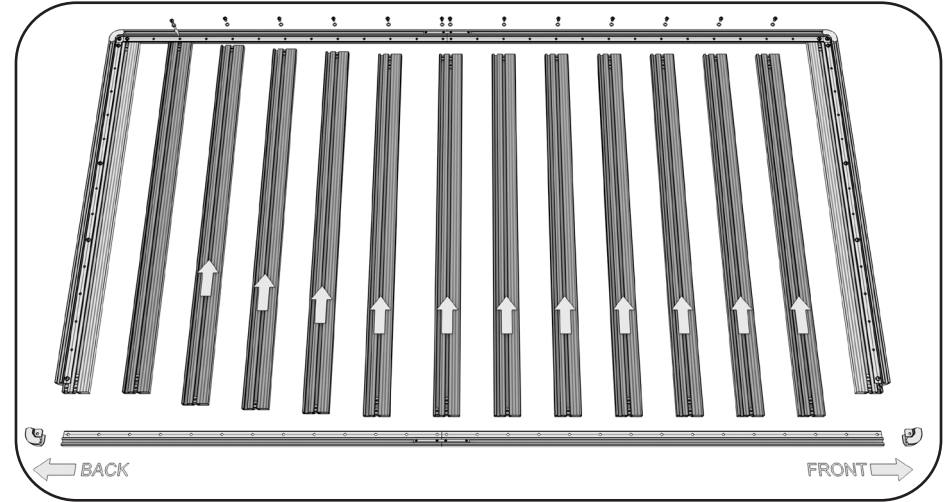
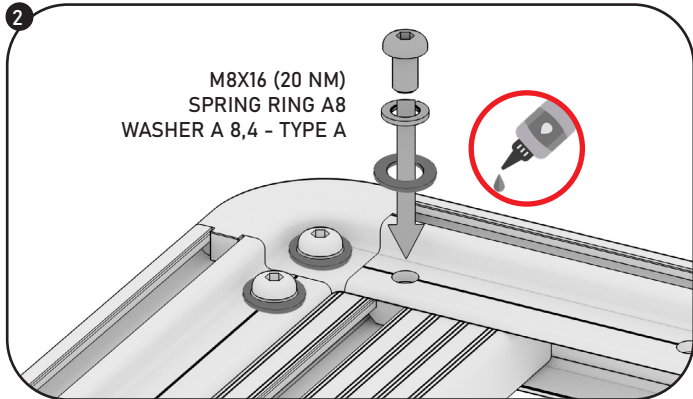
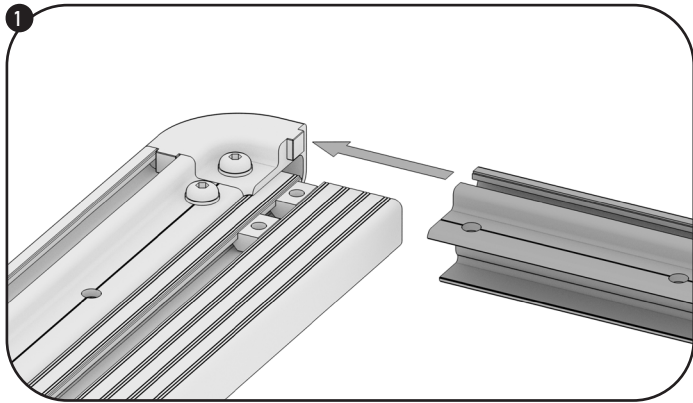
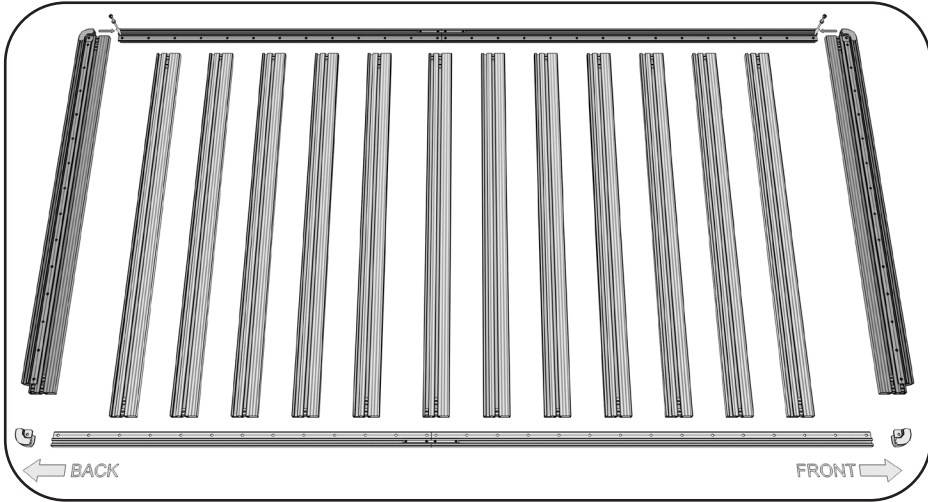

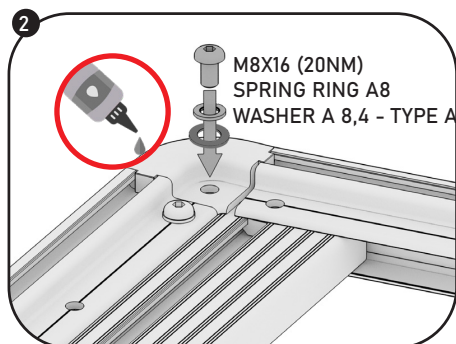
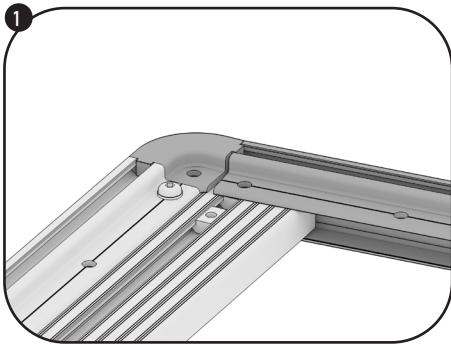
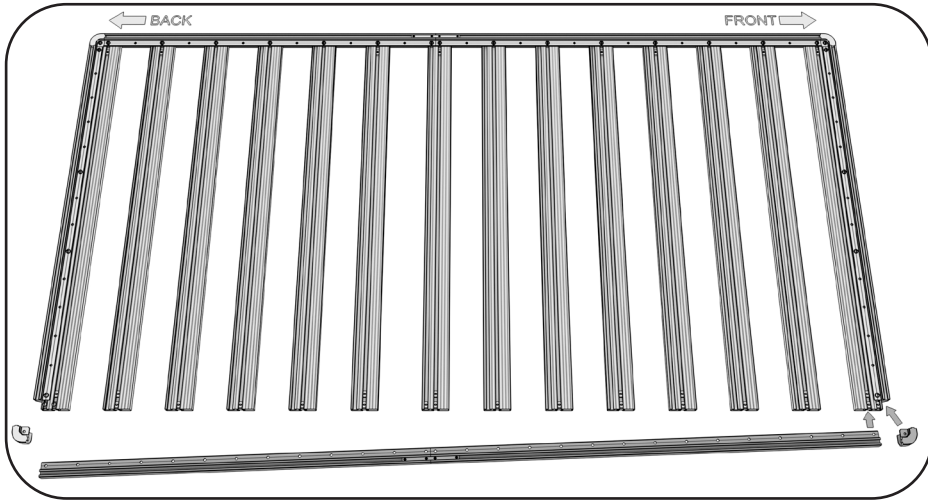

LOOK FOR CONNECT ALIGNMENT BEFORE TIGHTENING THE SCREWS.

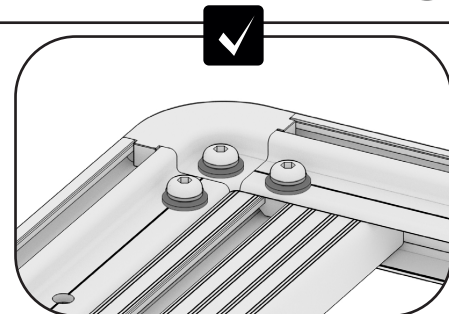
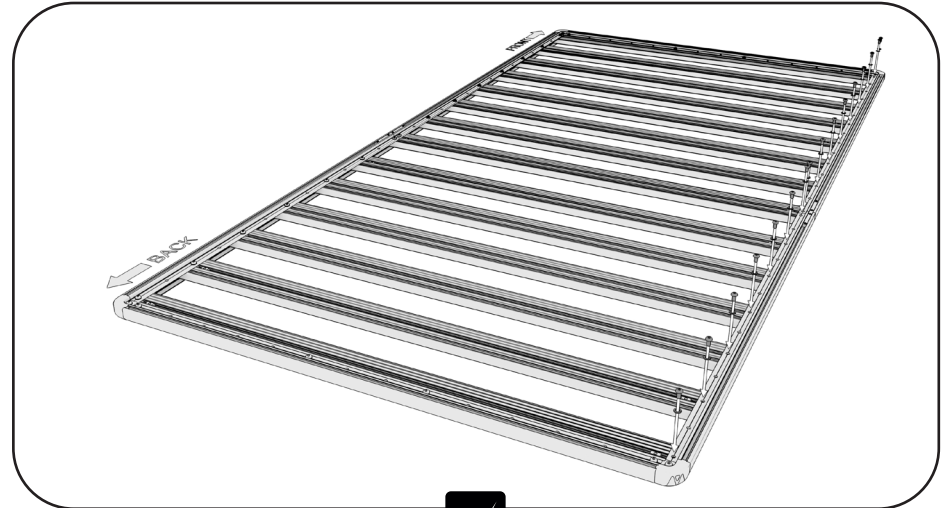
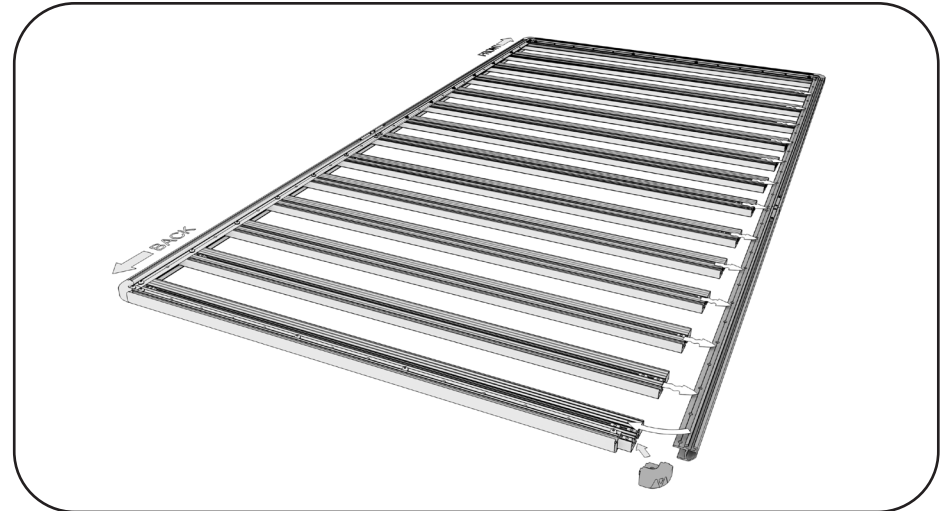
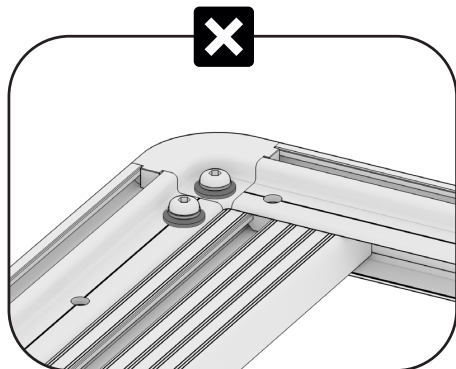
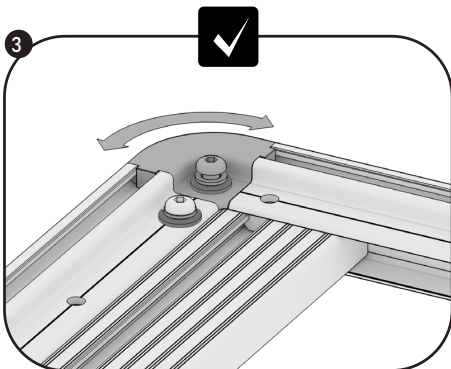

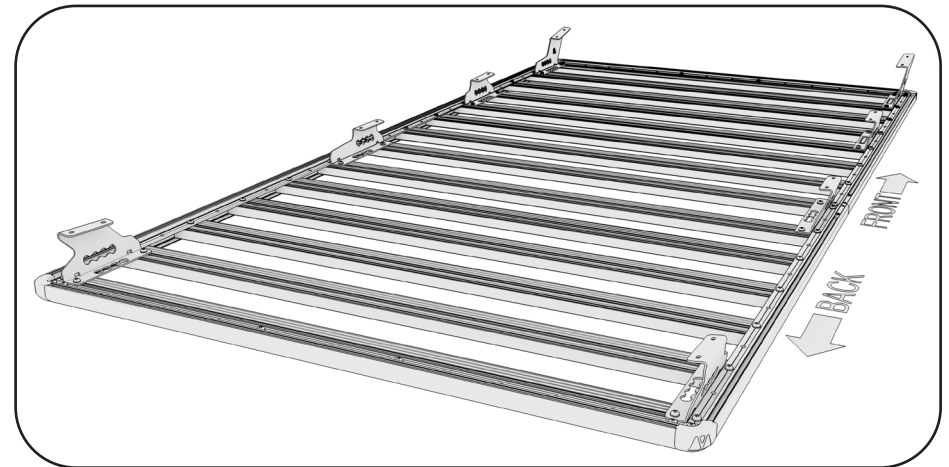
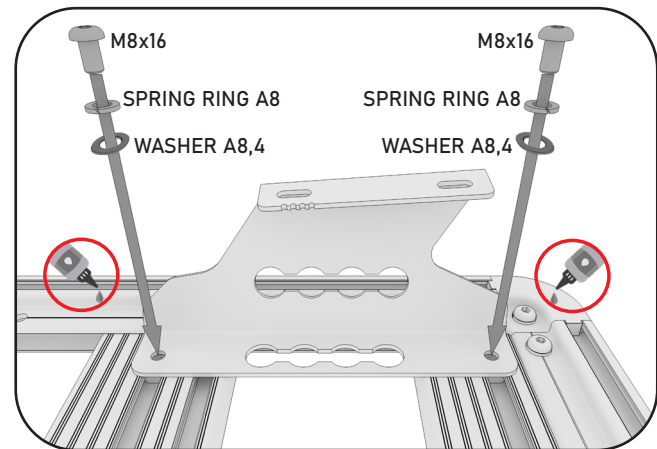
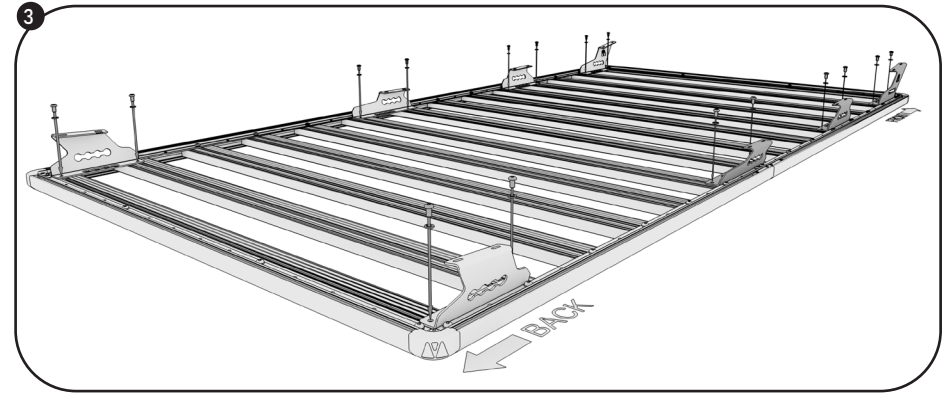
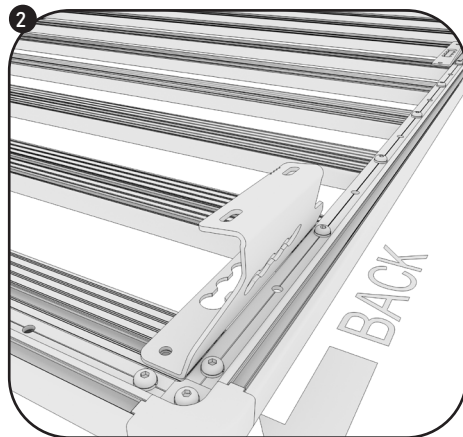
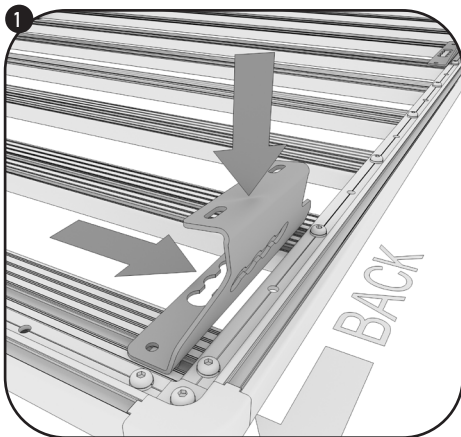
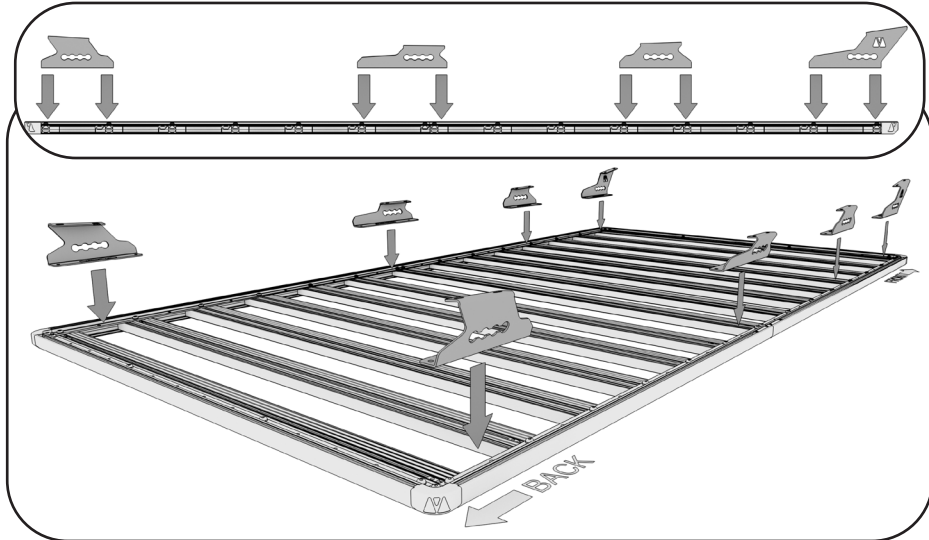
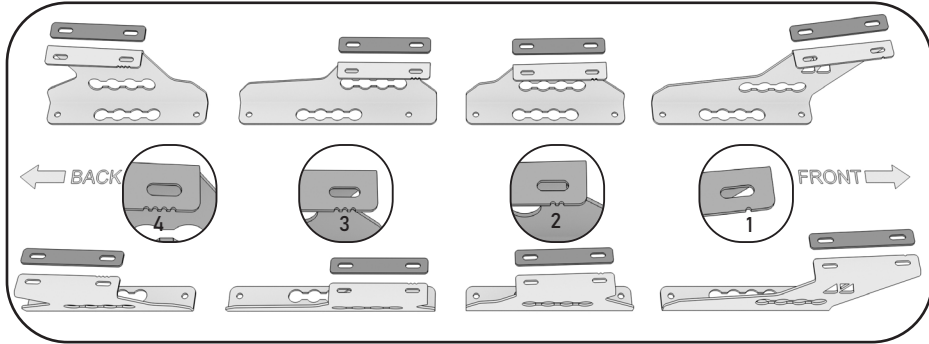

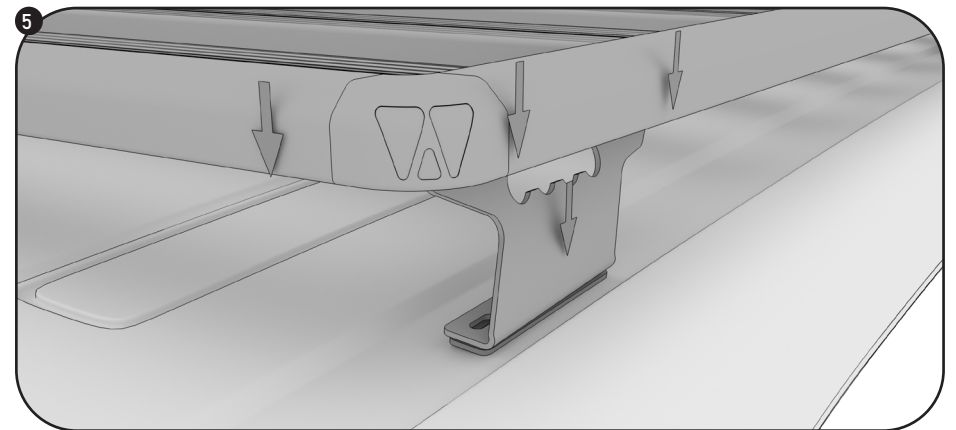
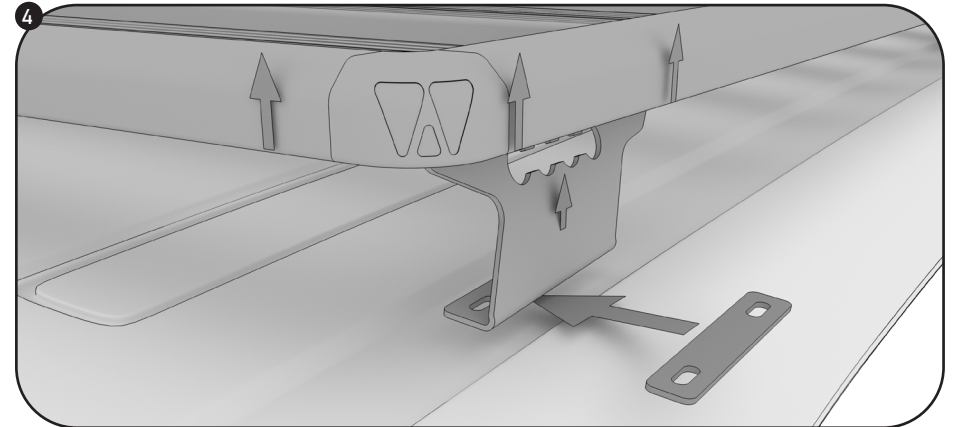
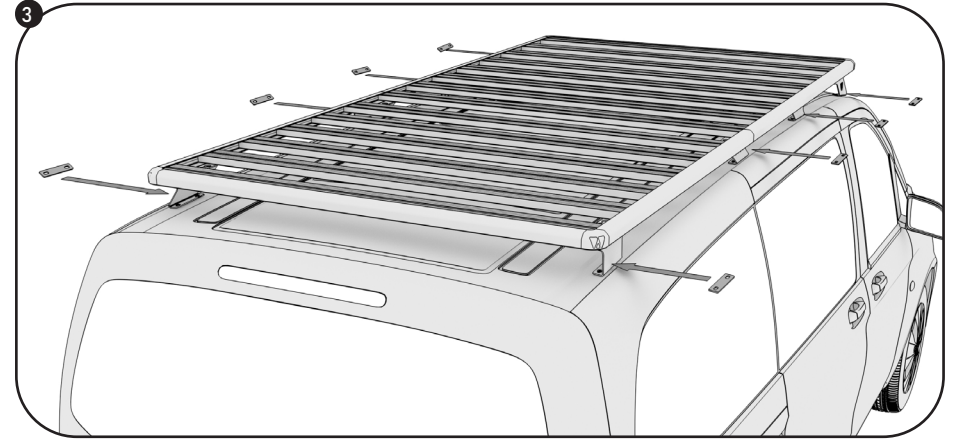
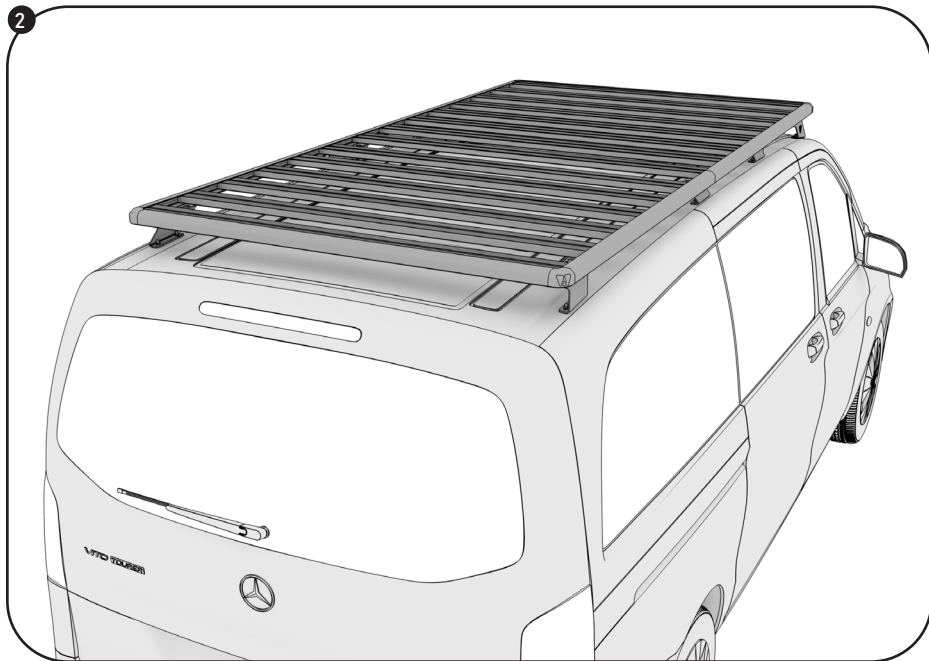
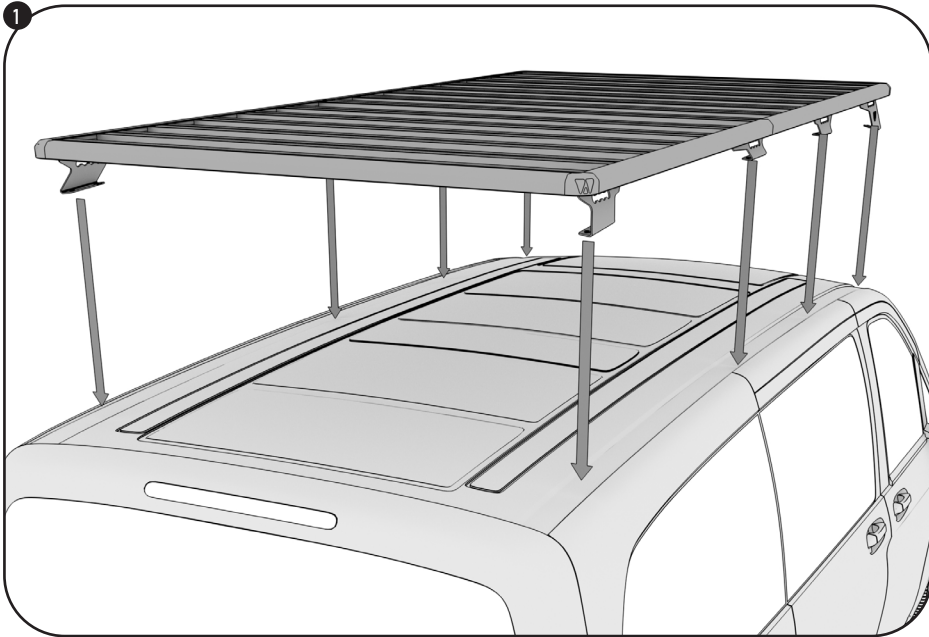

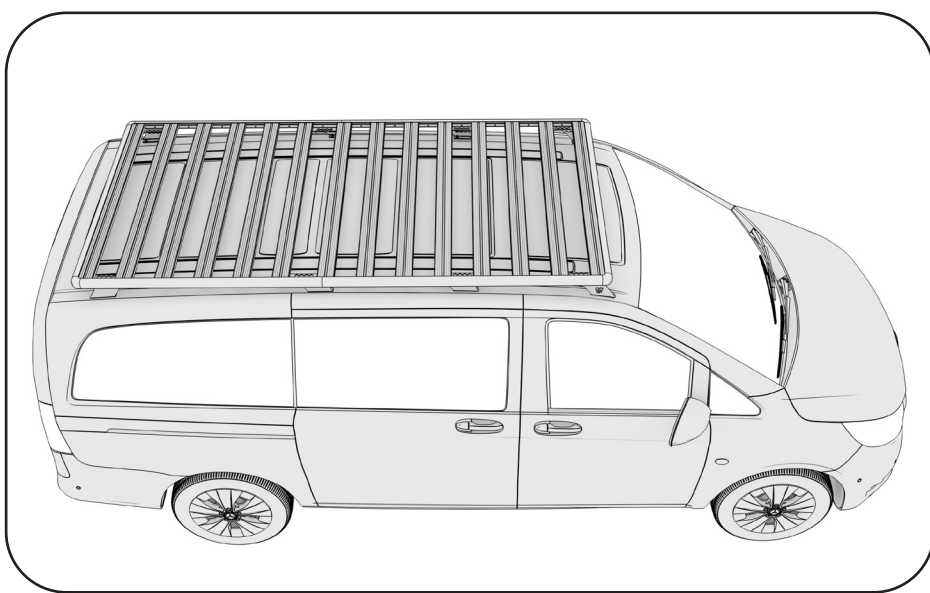
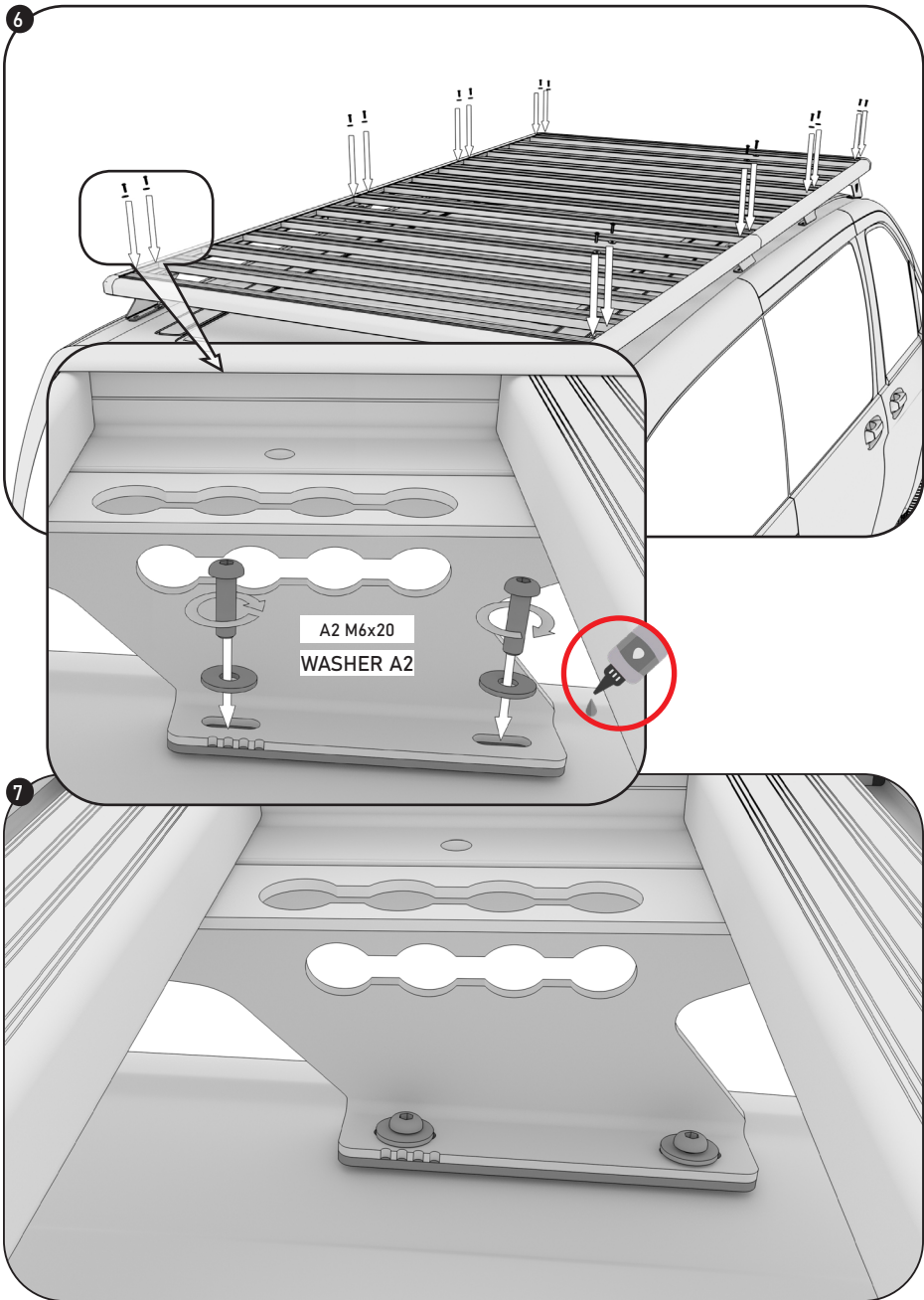

NOTES: _____

LOADING AND WEIGHT DISTRIBUTION

IN PRINCIPLE, THE ROOF LOAD OF THE VEHICLE MANUFACTURER APPLIES AND MUST NOT BE EXCEEDED (INCLUDING THE WEIGHT OF THE ROOF RACK 43,8 KG). IN OFFROAD USE THE MAXIMUM LOAD CAPACITY OF THE ROOF RACK IS REDUCED BY 50 %. LOADING MUST NOT TAKE PLACE SELECTIVELY, BUT MUST BE DISTRIBUTED EVENLY ON THE ROOF RACK INSTEAD. NO ONE-SIDED LOADING. THIS CAN HAVE A HUGE IMPACT ON THE DRIVING AND BRAKING PROPERTIES OF THE VEHICLE. THE LOAD TO BE TRANSPORTED MUST BE SECURELY LASHED USING APPROVED TENSIONING DEVICES.

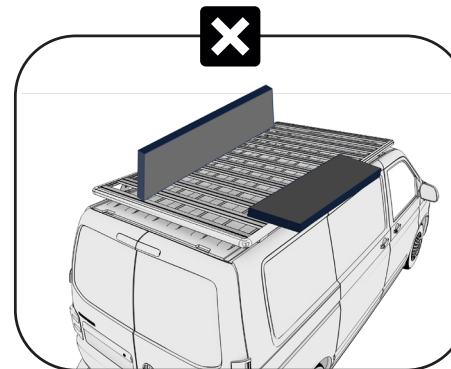
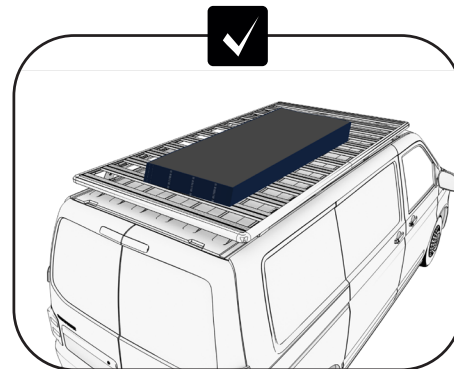
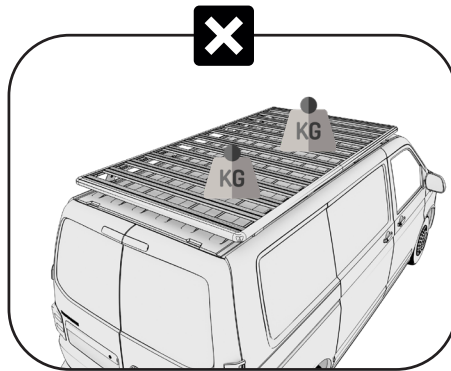
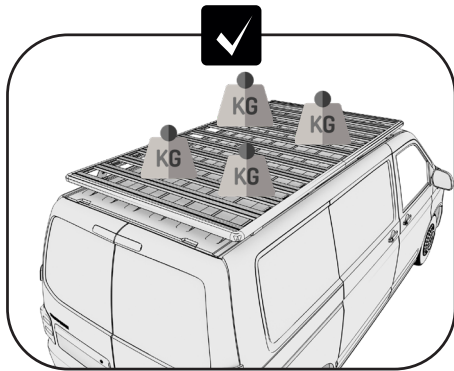

USAGE AND IMPORTANT INFORMATION

- BE AWARE OF THE CHANGED VEHICLE HEIGHT
- RECOMMENDED TOP SPEED WITH ROOF RACK:
WITHOUT ADDITIONAL LOAD: 100 KM/H
WITH ADDITIONAL LOAD: 80 KM/H
- DO NOT DRIVE THROUGH THE CAR WASH WITH YOUR ROOF RACK MOUNTED
- THE FUNCTION OF YOUR SLIDING ROOF MIGHT BE RESTRICTED; OPENING IT MIGHT LEAD TO ITS DESTRUCTION

CARE INSTRUCTIONS

THERE ARE A FEW SIMPLE AND EASY STEPS YOU WILL NEED TO TAKE CARE OF, IN ORDER TO MAINTAIN FULL FUNCTIONALITY OF YOUR VICKYWOOD ROOF RACK AND KEEP IT IN ITS CLEAN STATE:

- RINSE WITH CLEAN WATER AND WIPE IT OFF WITH A SOFT MICROFIBER CLOTH
- FOR MORE INTENSE DIRT YOU CAN USE A SOFT BRUSH AND SOME SOAP - DO NOT USE ANY AGGRESSIVE CHEMICAL CLEANERS
- DO NOT USE STEAM CLEANER OR HIGH PRESSURE CLEANER
- DURING WINTER MAKE SURE TO RINSE OF ROAD SALT AS SOON AS POSSIBLE AS WELL AS IN COASTAL REGIONS WITH SALTY AIR

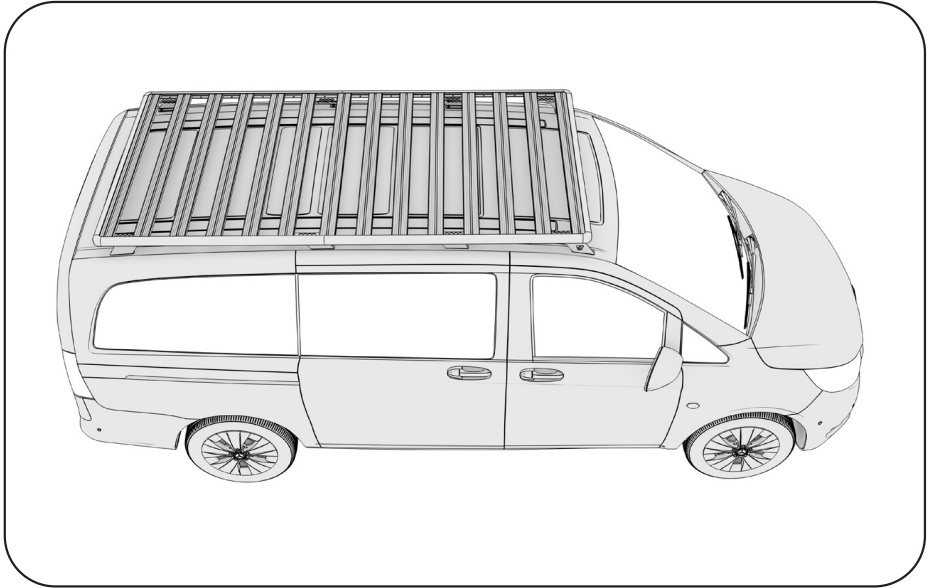

MORE INFORMATION ABOUT VICKYWOOD ROOF TENTS & CAMPING EQUIPMENT

 VICKYWOOD.COM

 @VICKYWOOD_CAMP

JOIN OUR COMMUNITY ON FACEBOOK:

 VICKYWOODIES | DIE DACHZELT-COMMUNITY

SHOW US YOUR TRAVELS
#ROOFRACKBYVICKYWOOD

VW-RR-MM-MV-14



4260357368956